

# BERGEN BUILDING ENVELOPE STABILIZATION

1932 Arthur Avenue, Bronx, New York

## PRESENTATION TO COMMUNITY BOARD 6

01/20/2026



# LOCATION



# LOCATION

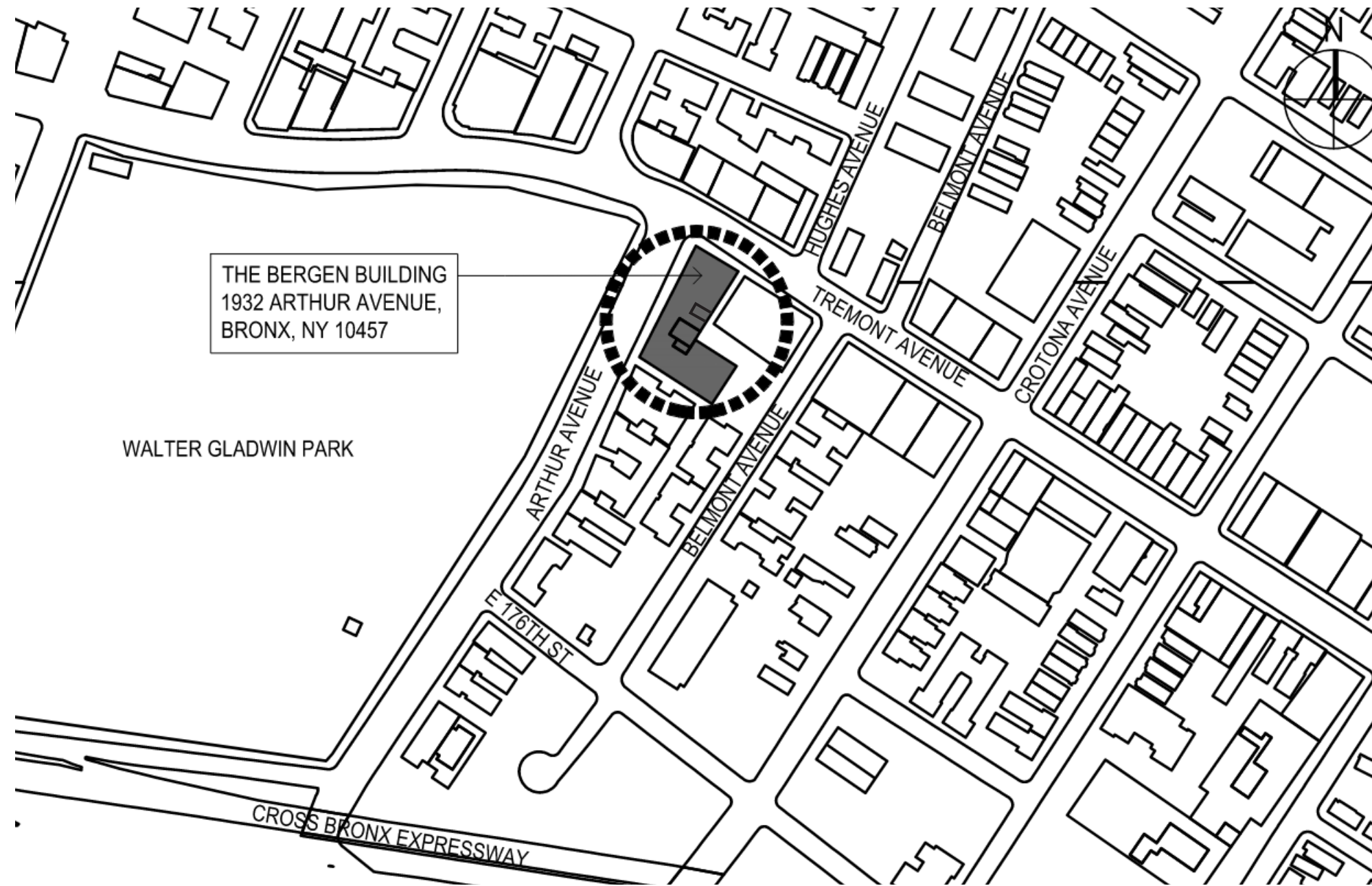

THE BERGEN BUILDING  
1932 ARTHUR AVENUE,  
BRONX, NY 10457

WALTER GLADWIN PARK



# SITE PHOTOS

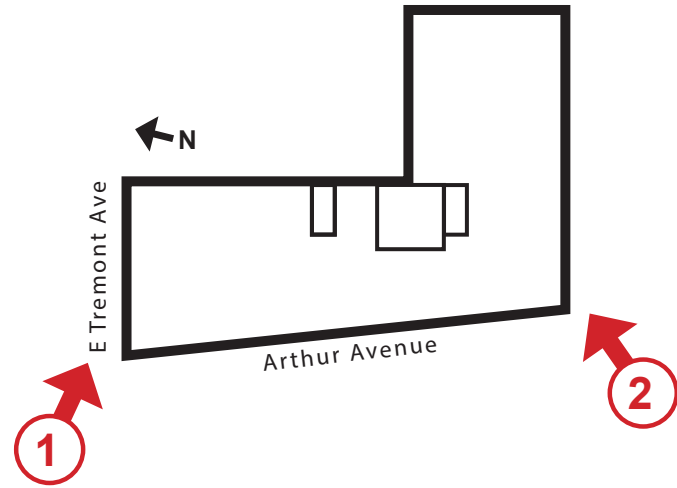

- Replace windows
- Glazed brick, stone and concrete repair
- Replace entrance doors
- Install ADA ramp at 1918 Arthur Ave entrance
- Replace roll-up security door



1: Northwest Building Corner at E. Tremont Ave and Arthur Ave



2: Southwest Building Corner at Adjacent Building on Arthur Ave

# SITE PHOTOS

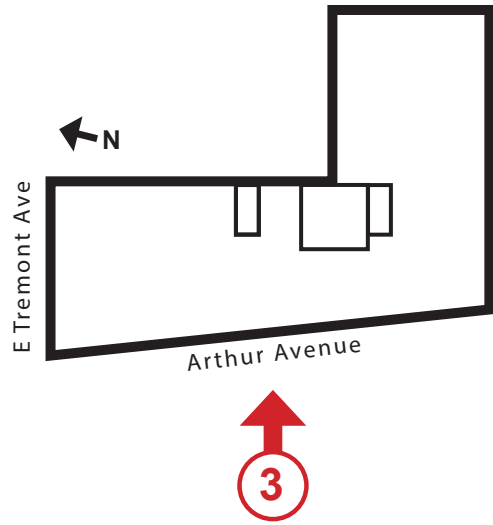

- Replace windows
- Glazed brick, stone and concrete repair
- Replace entrance doors
- Install ADA ramp at 1918 Arthur Ave entrance
- Replace roll-up security door



3: View of West Elevation at Arthur Ave

# SITE PHOTOS

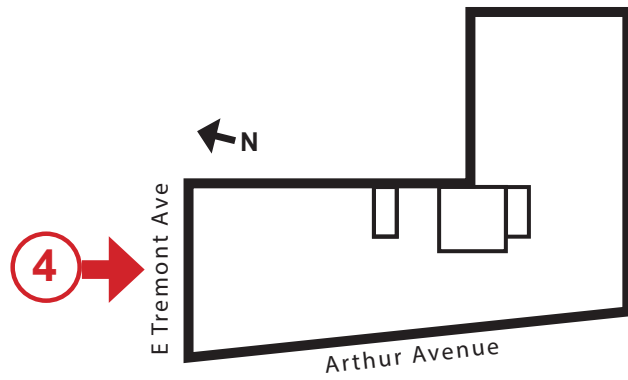

- Replace windows
- Glazed brick, stone and concrete repair
- Replace entrance door
- Replace roll-up security door



DESIGNERS  
EDGE

4: View of North Elevation at E. Tremont Ave

# SITE PHOTOS

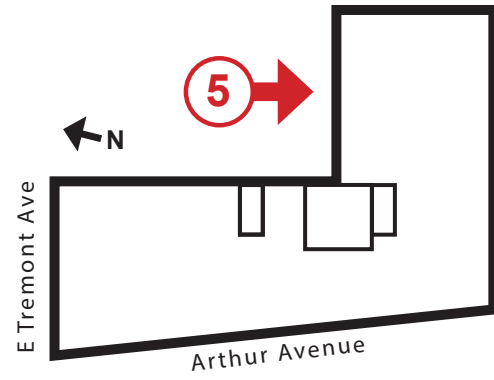

- Replace windows
- Common brick repair
- Install rainscreen



5: View of North Elevation at Rear Yard

# SITE PHOTOS

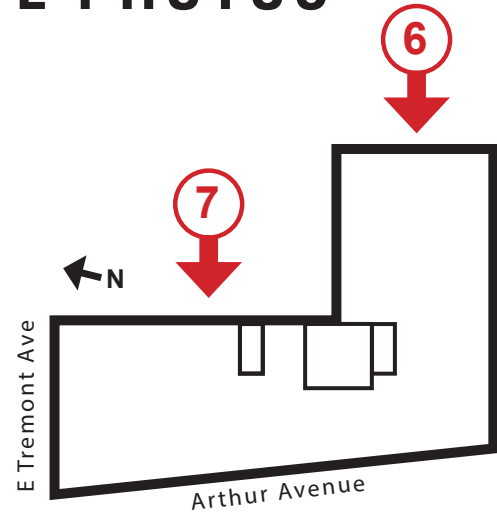

- Replace windows
- Common brick repair
- Install rainscreen



6: View of East Elevation at Rear Yard



7: View of East Elevation at Rear Yard

# SITE PHOTOS

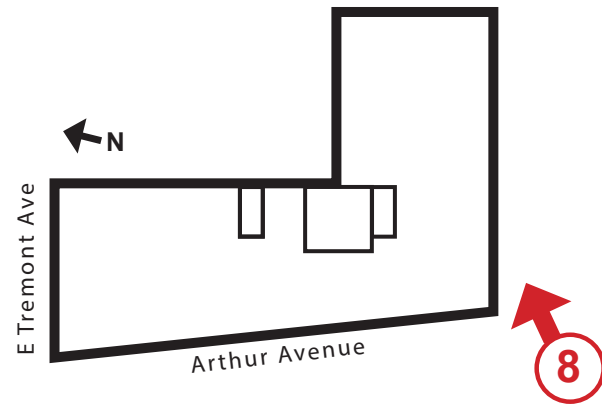

- Replace windows
- Common brick repair
- Install rainscreen



8: View of South Elevation at Rear Yard

# SITE PHOTOS

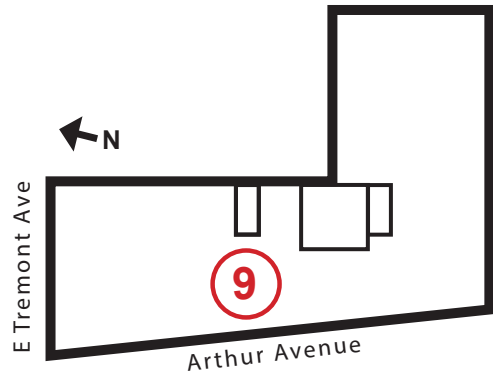

- Replace roofing membrane
- Install PV panels
- Replace coping stones at bulkheads



9: Aerial View of Roof

# SITE PHOTOS

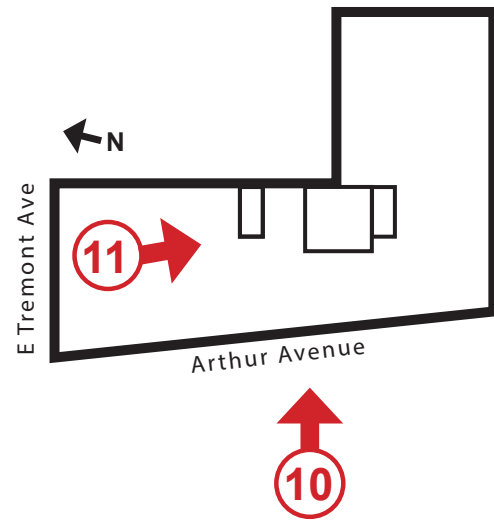

- Replace roofing membrane
- Install PV panels
- Replace coping stones at bulkheads
- Replace doors and windows
- Install rainscreen
- Replace steel ladders



10: View of West Elevation at Elevator Machine Room and Bulkhead B (beyond)



11: View of North Elevation at Bulkhead B and Elevator Machine Room (beyond)

# SITE PHOTOS

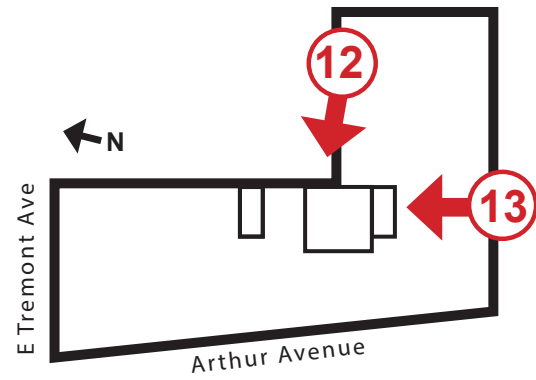

- Replace roofing membrane
- Install PV panels
- Replace coping stones at bulkheads
- Replace doors and windows
- Install rainscreen
- Replace steel ladders



12: View of East Elevation (from left): Bulkhead A, Elevator Machine Room and Bulkhead B



13: View of South Elevation at Bulkhead A and Elevator Machine Room (beyond)

# SUMMARY OF SCOPE OF WORK

## SITE WORK

- Replace areaway concrete slab and drains
- Repair retaining wall
- Install bike racks
- Install ADA ramp

## FAÇADE

### E. TREMONT AND ARTHUR AVE FAÇADES:

- Replace windows
- Glazed brick, stone and concrete repair
- Replace entrance doors
- Install ADA ramp at 1918 Arthur Ave entrance
- Replace roll-up security doors

### REAR AND SIDE YARD FAÇADES:

- Replace windows
- Common brick repair
- Install rainscreen

# SUMMARY OF SCOPE OF WORK

## ROOF WORK

- Replace roofing membrane
- Install PV panels
- Replace coping stones at bulkheads
- Replace doors and windows
- Install rainscreen
- Replace steel ladders

## INTERIOR WORK

### E. TREMONT AND ARTHUR AVE FAÇADES:

- Restore bronze base for revolving doors at Arthur Ave vestibules
- Remove plaster at existing masonry wall
- Remove and reinstall radiators and associated steam pipe
- Relocate outlets associated with interior insulation
- Install insulation, vapor barrier, metal stud, gypsum board and paint

### REAR AND SIDE YARD FAÇADES:

- Relocate A/C outlets

# SITE PLAN

- Replace areaway concrete slab and drains
- Repair retaining wall
- Install bike racks
- Install ADA ramp

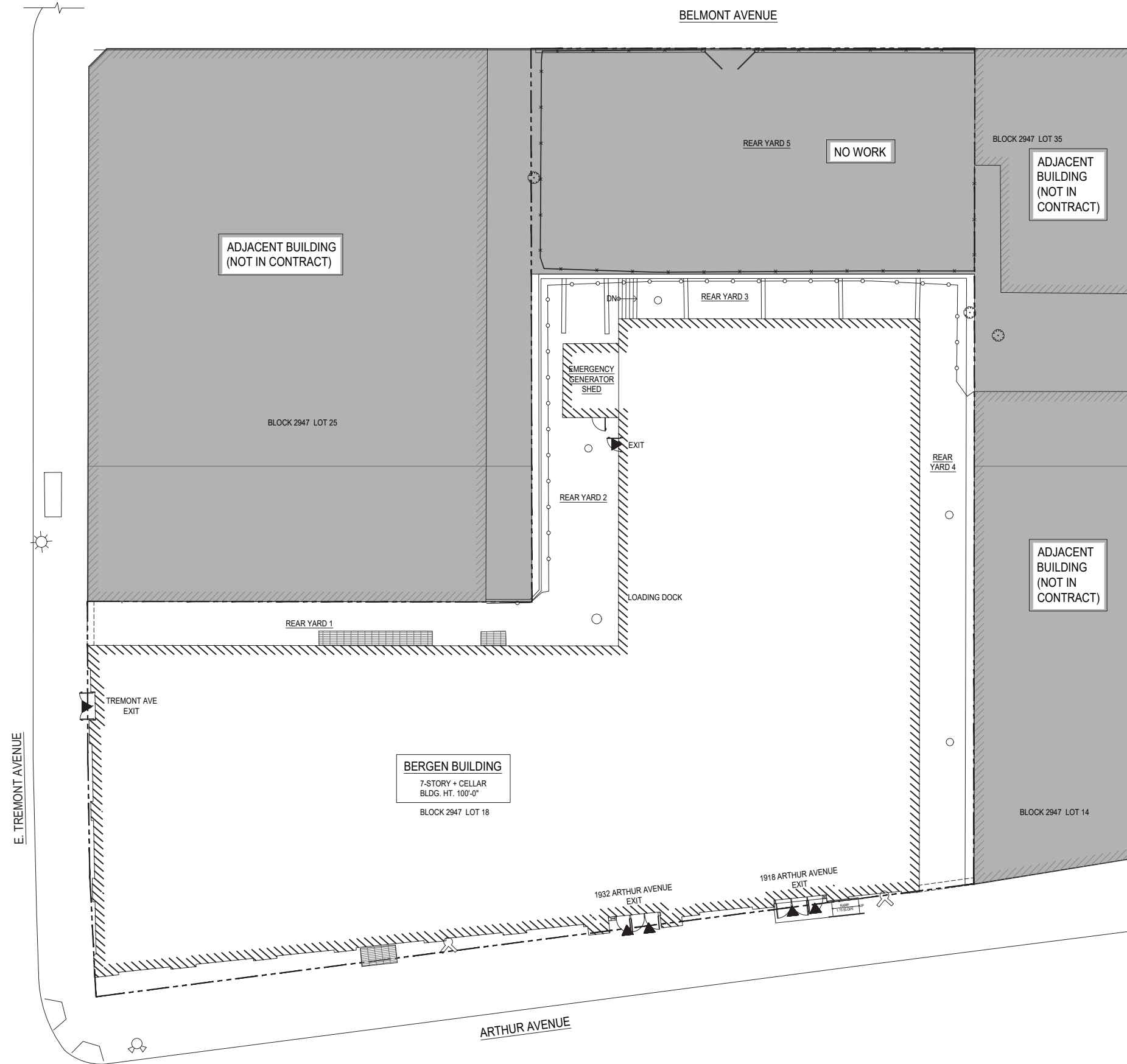

# PROPOSED ELEVATIONS

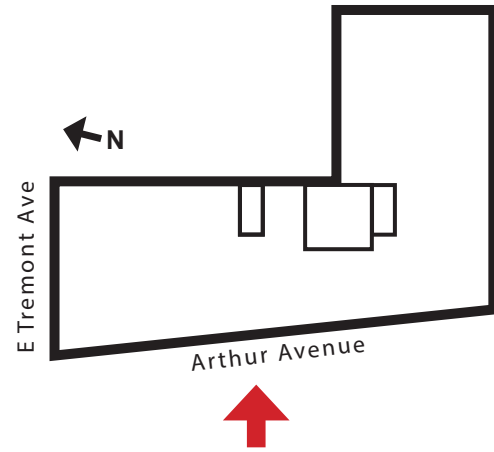

- Replace windows
- Glazed brick, stone and concrete repair
- Replace entrance doors
- Install ADA ramp at 1918 Arthur Ave entrance
- Replace roll-up security door



# PROPOSED ELEVATIONS

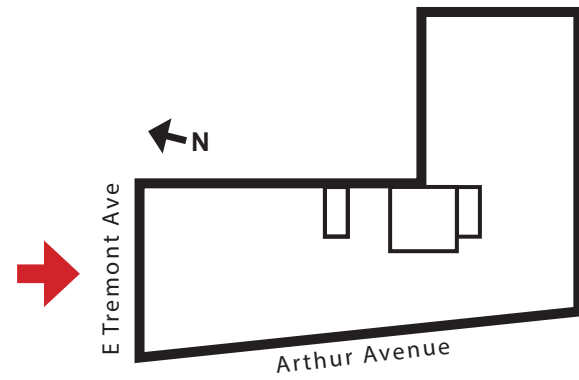

- Replace windows
- Glazed brick, stone and concrete repair
- Replace entrance door
- Replace roll-up security door

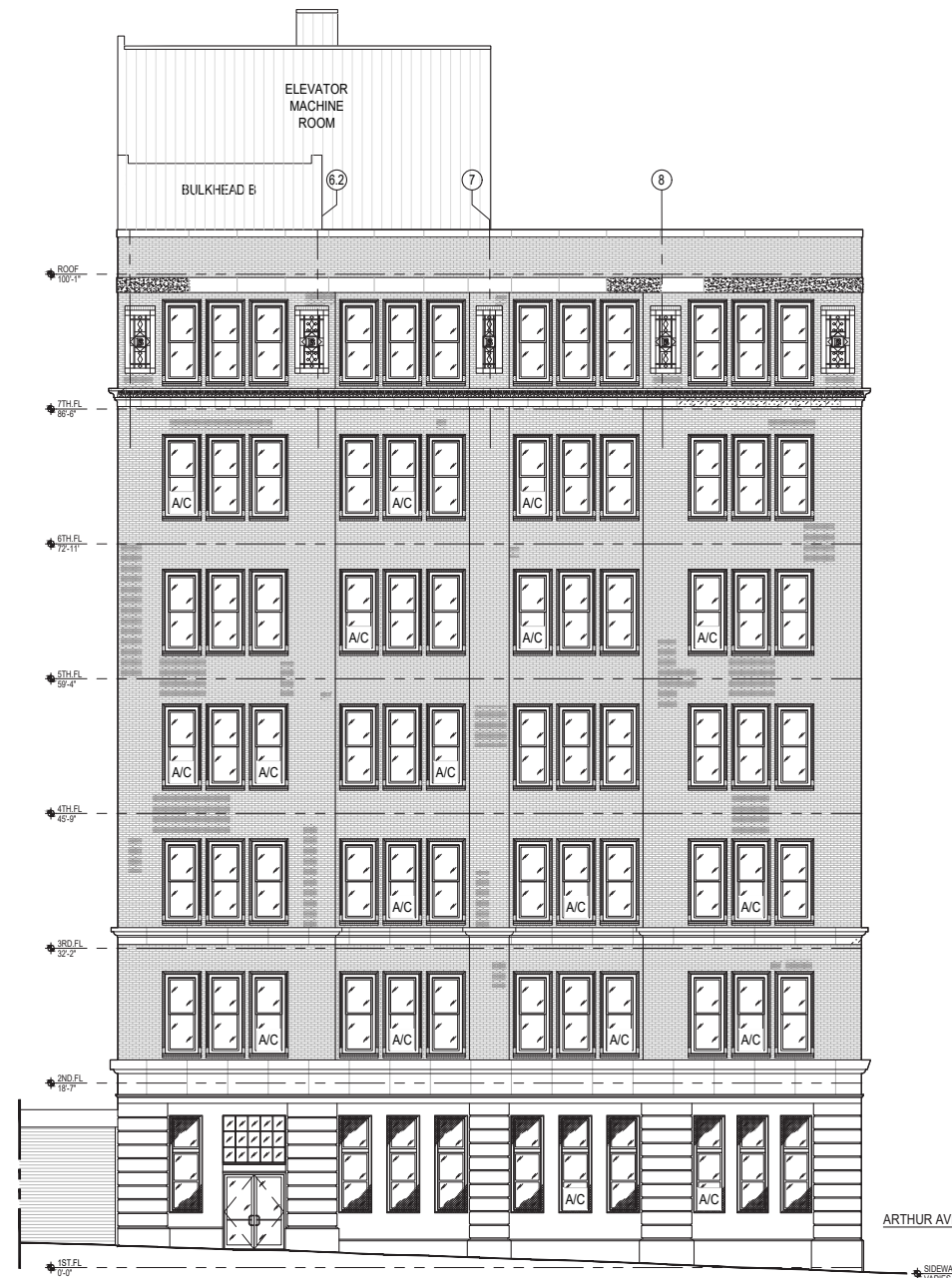

# PROPOSED ELEVATIONS

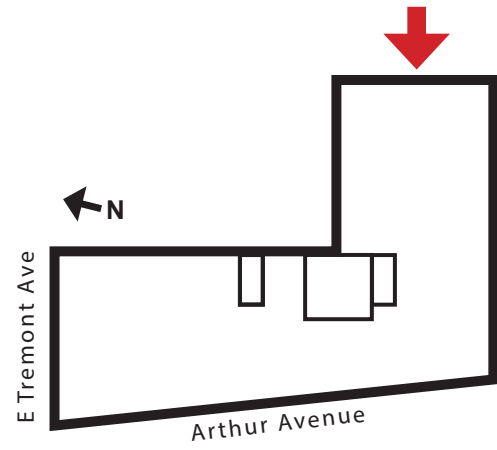

- Replace windows
- Install rainscreen

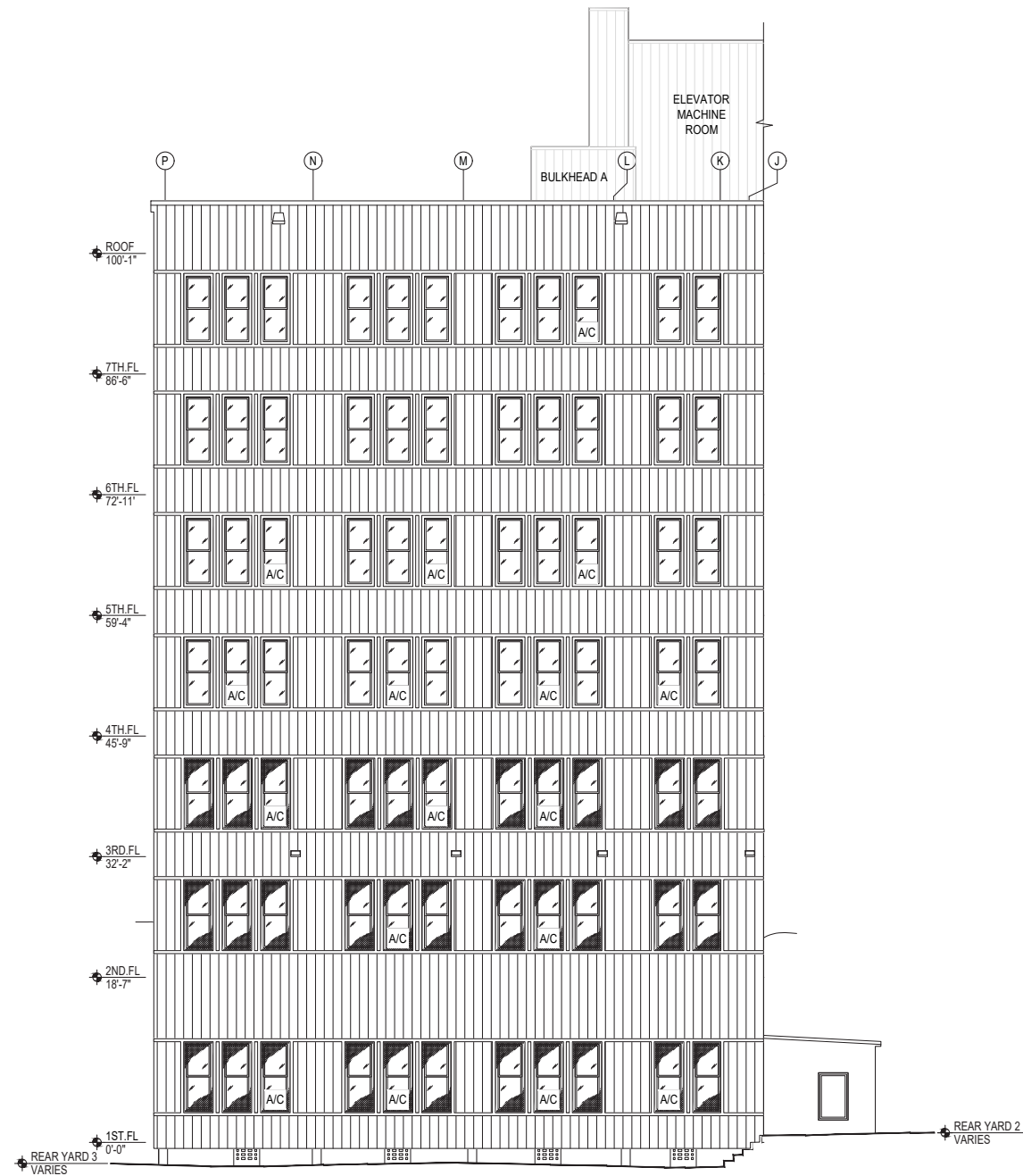

# PROPOSED ELEVATIONS

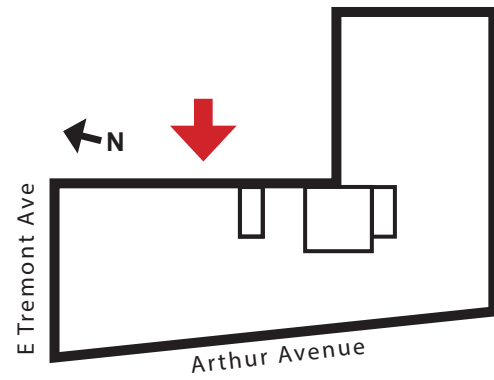

- Replace windows
- Install rainscreen



# PROPOSED ELEVATIONS

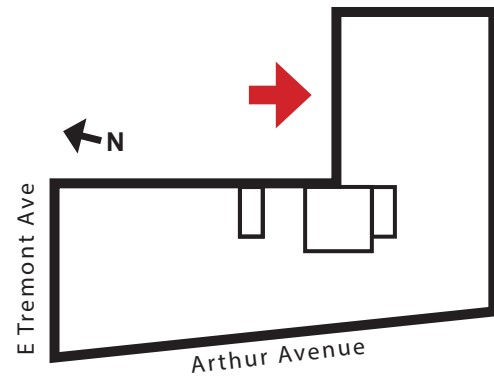

- Replace windows
- Install rainscreen

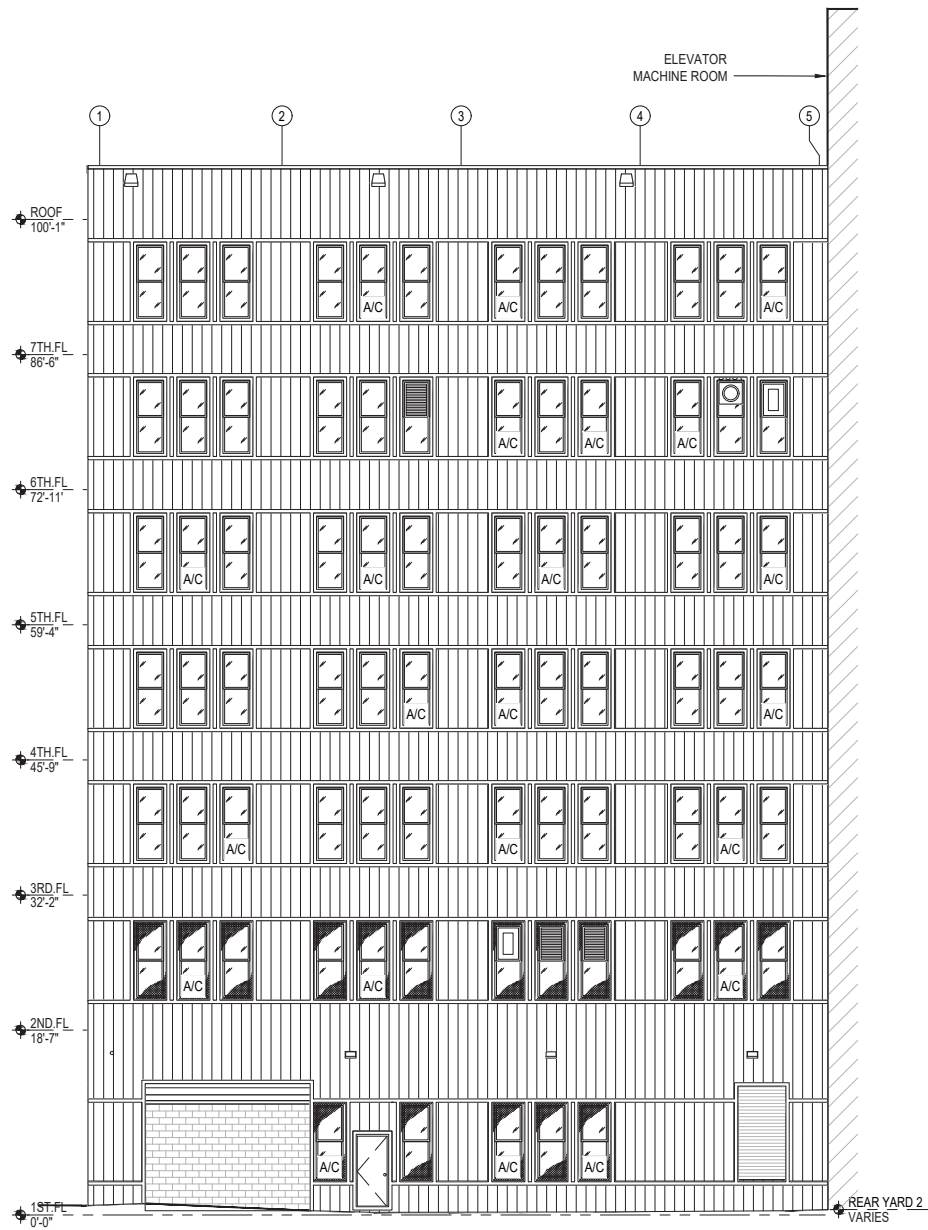

# PROPOSED ELEVATIONS

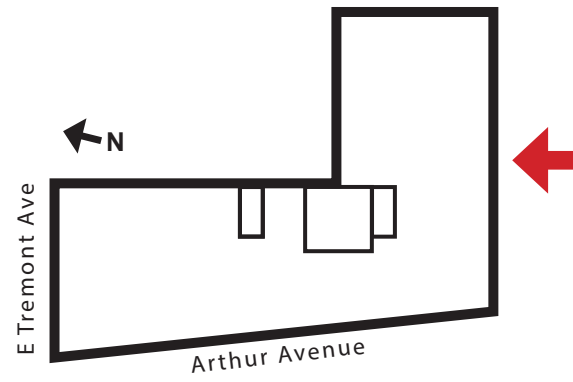

- Replace windows
- Install rainscreen

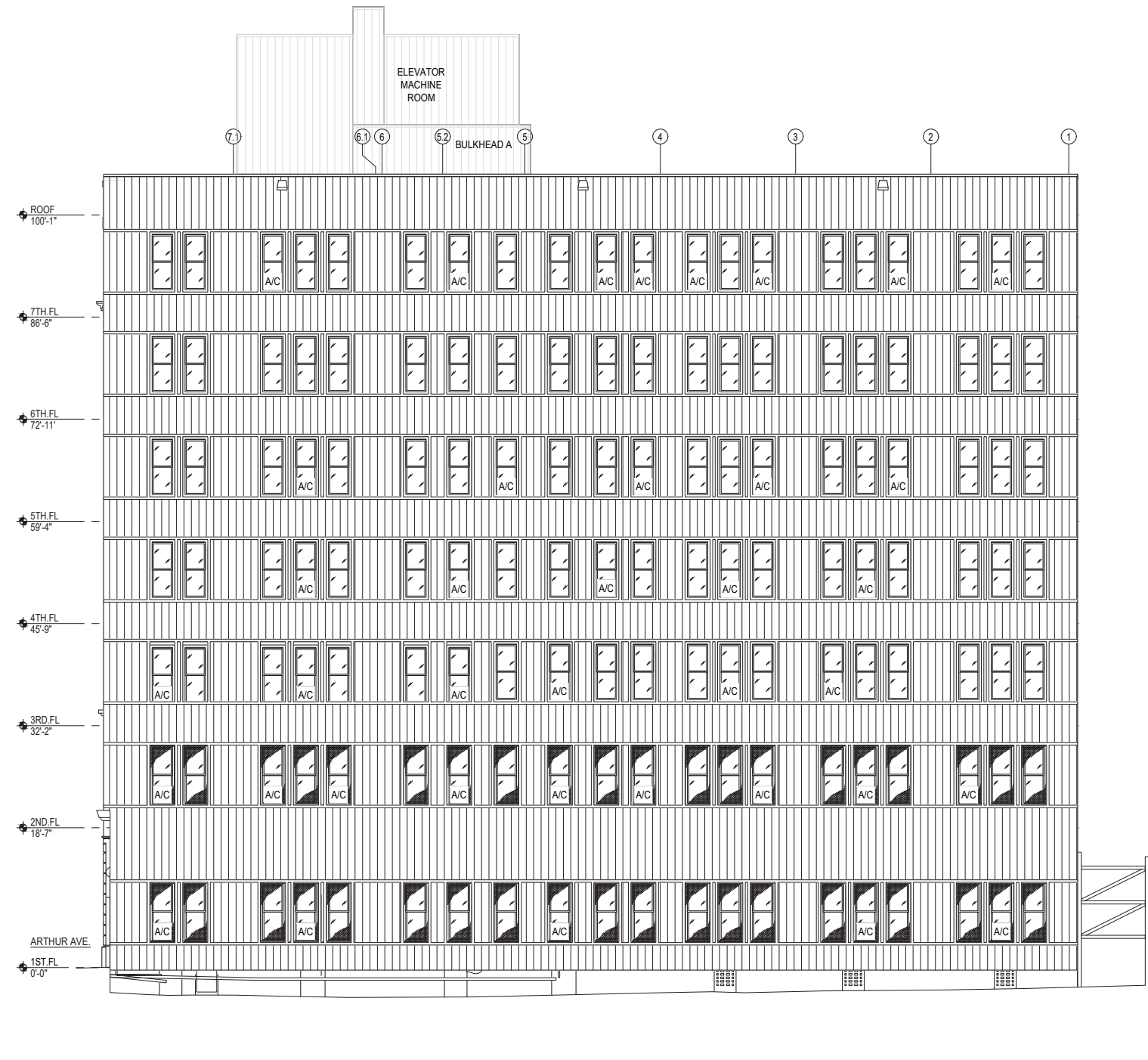

# VISUALIZATIONS

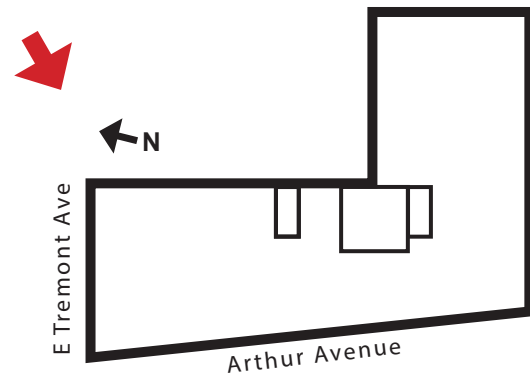

- Replace windows
- Glazed brick, stone and concrete repair at E. Tremont Ave Facade
- Install rainscreen at rear yard facades



# VISUALIZATIONS

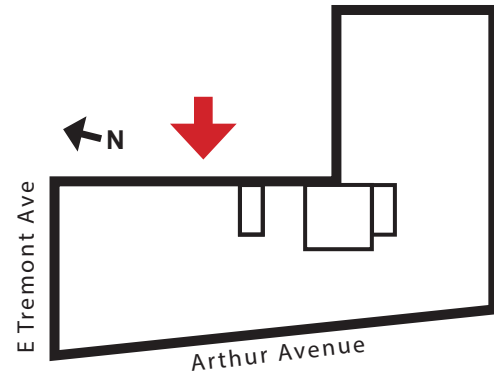

- Replace windows
- Install rainscreen

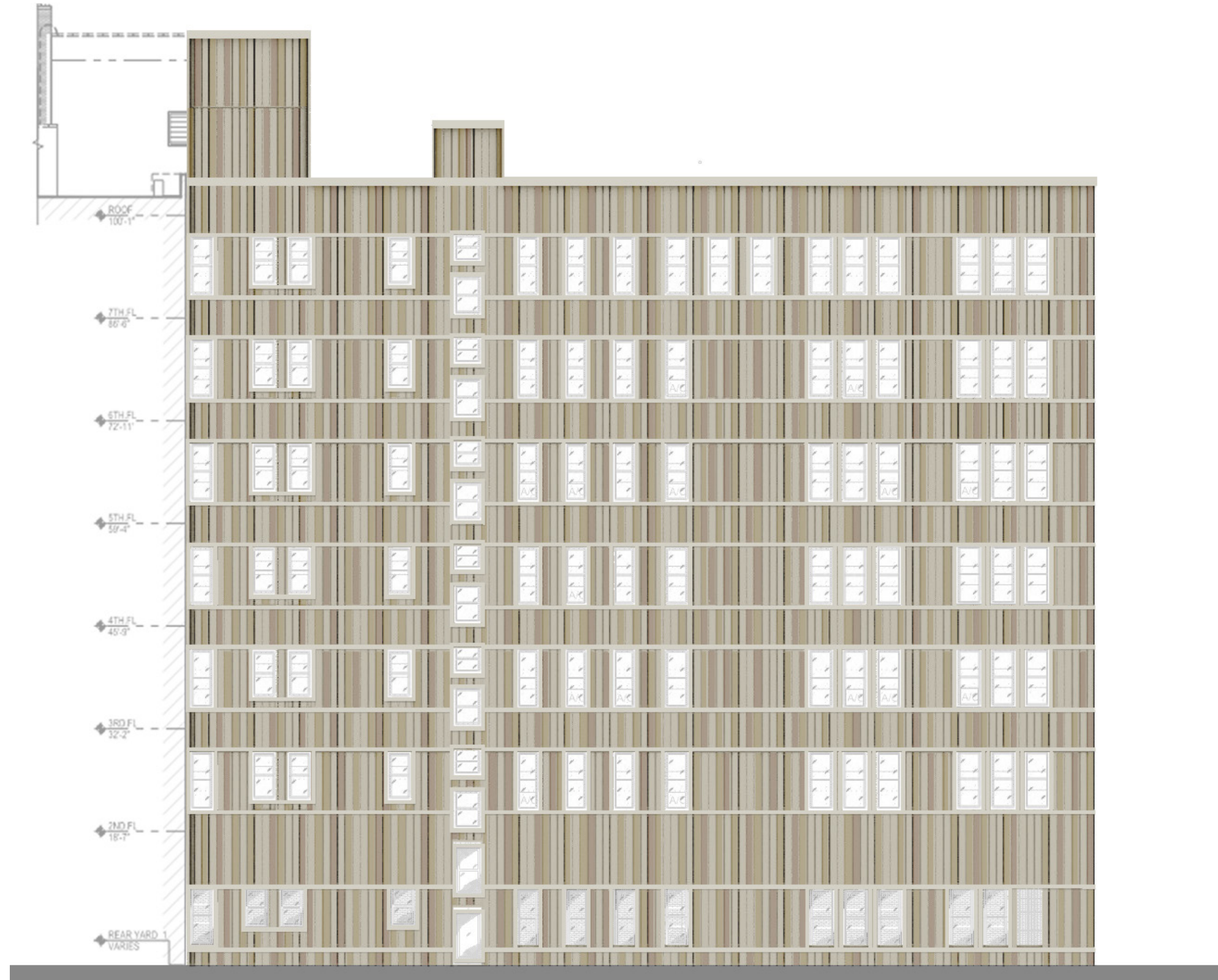

# ENTRANCE DOORS

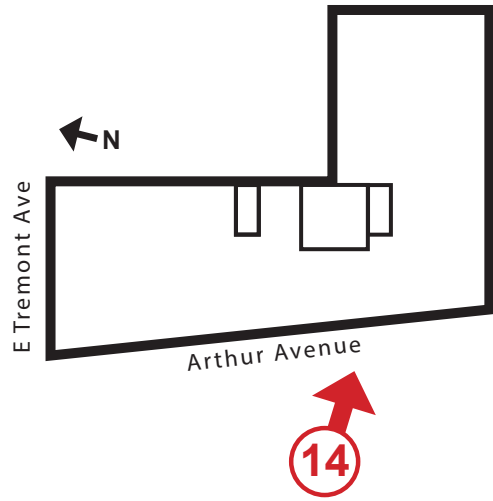

- ADA compliant doors



14: Entrance Door on Arthur Ave no. 1932



14A: Proposed Entrance Door on Arthur Ave no. 1932

# ENTRANCE DOORS

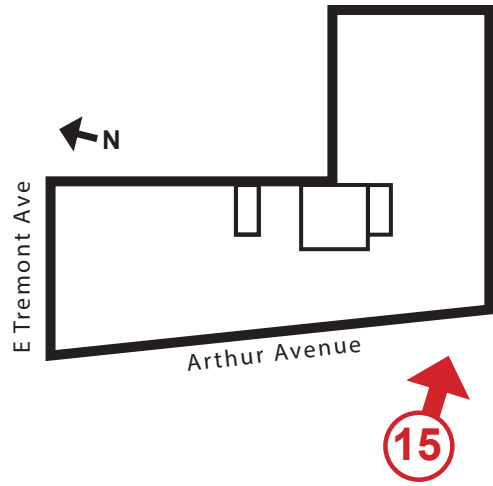

- Ramp and ADA compliant doors



15: Entrance Door on Arthur Ave no. 1918



15A: Proposed Entrance Door on Arthur Ave no. 1918

# ENTRANCE DOORS

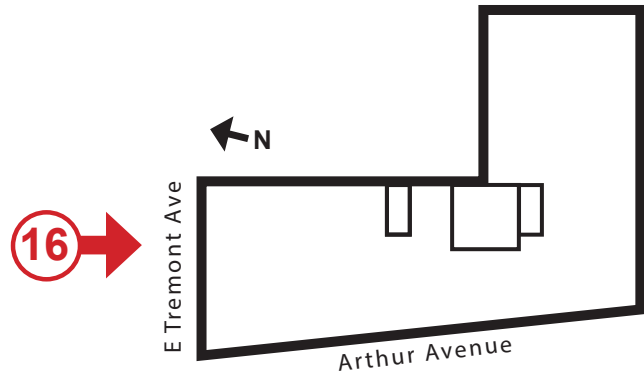

- Replace entrance door



16: Entrance Door on E. Tremont Ave



16A: Proposed Entrance Door on E. Tremont Ave

# INTERIORS

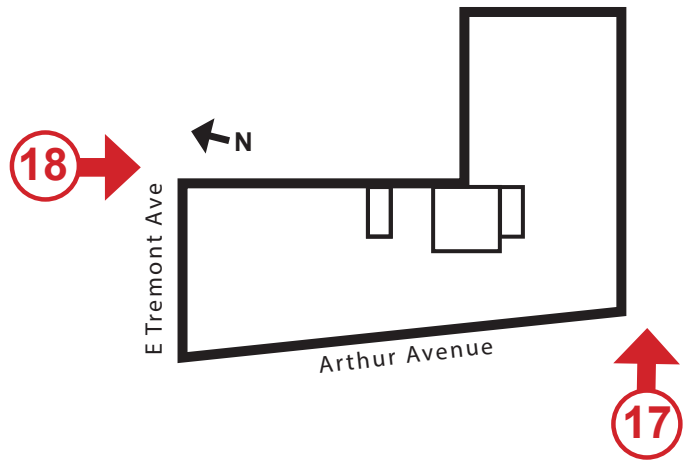

- Replace roll-up security doors



17: Roll-up Security Door on Arthur Ave



18: Roll-up Security Door on E. Tremont Ave

# SITE PHOTOS



Typical Existing Windows at Street Facades



Typical Existing Window Grille at Street Facades

# SITE PHOTOS



Typical Existing Windows at Rear Yard Facades



Typical Existing Window Grille at Rear Yard Facades

# VISUALIZATIONS

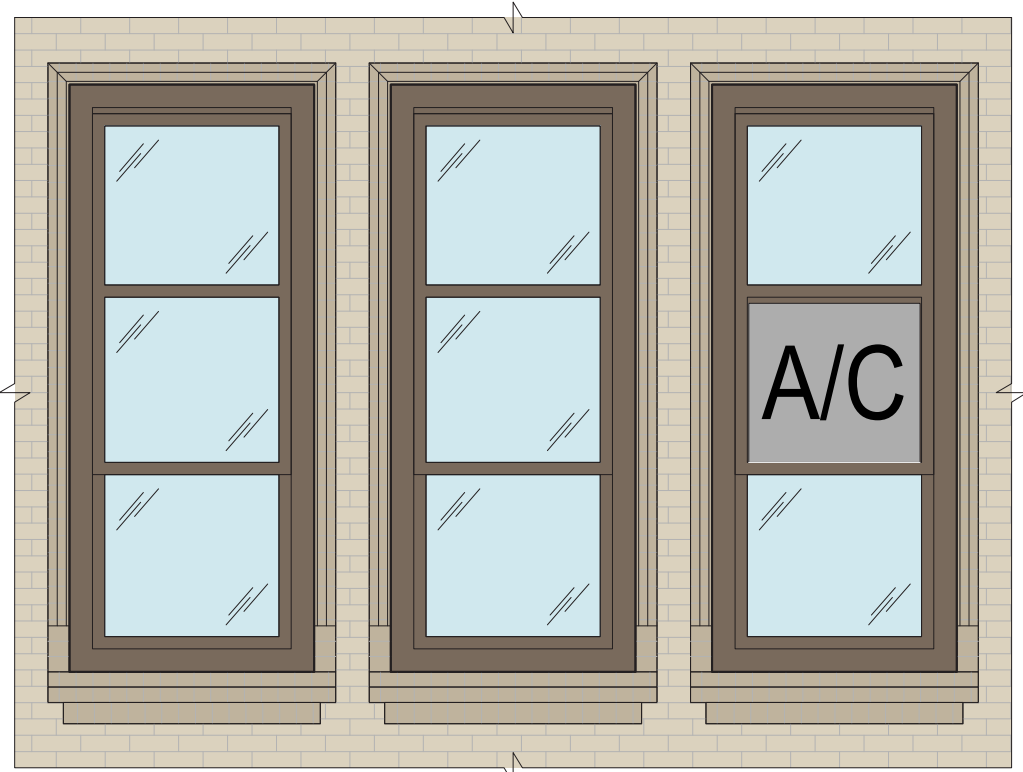

Existing Windows at Street Facades

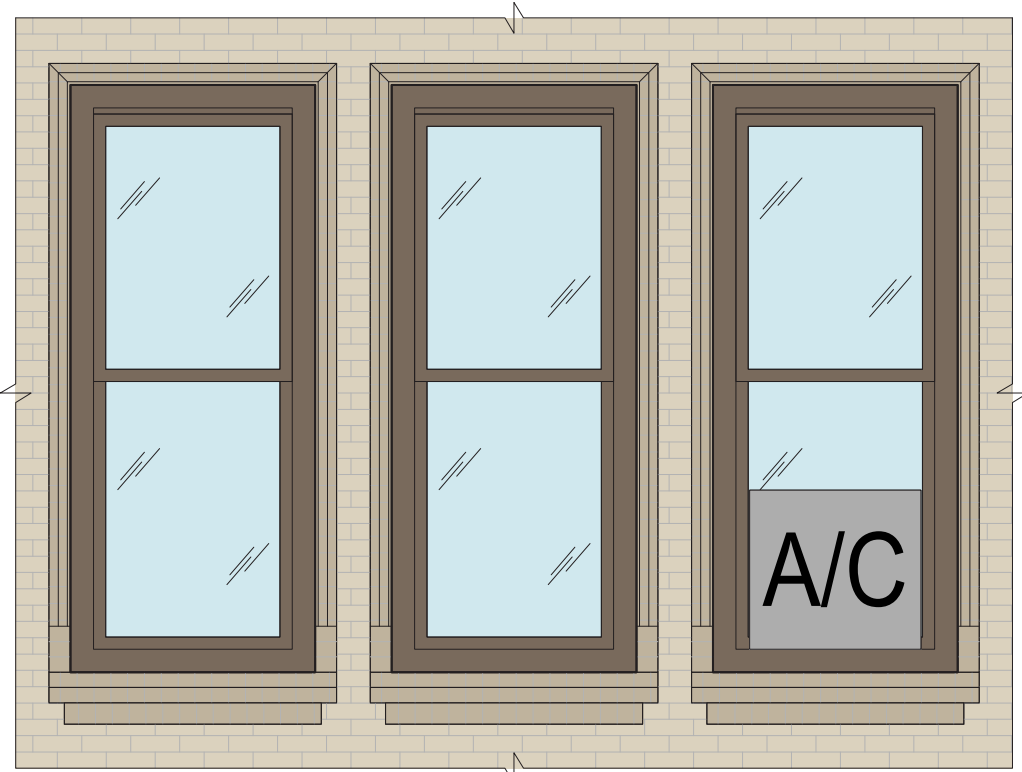

Proposed Windows at Street Facades

# VISUALIZATIONS

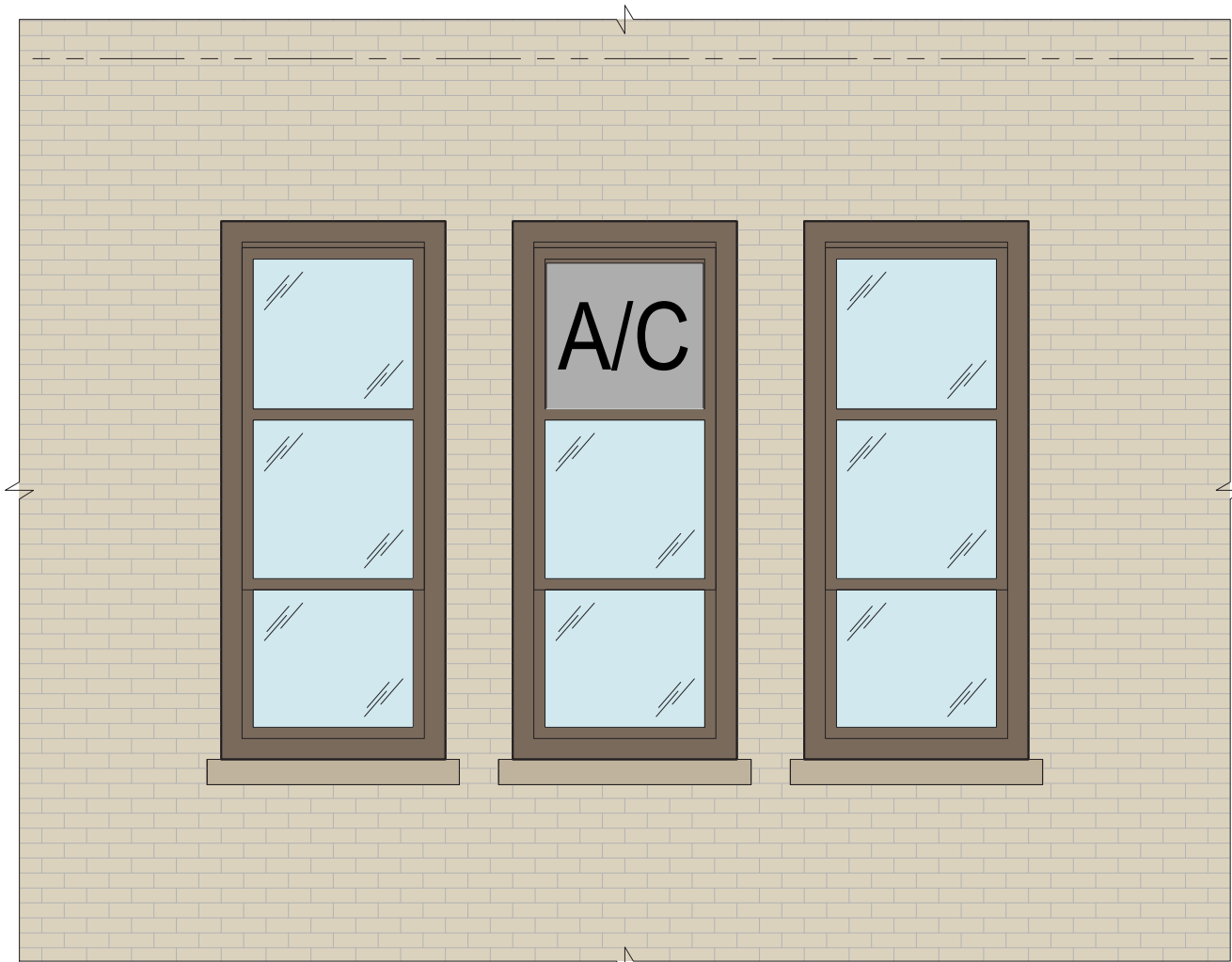

Existing Windows at Rear Yard Facades

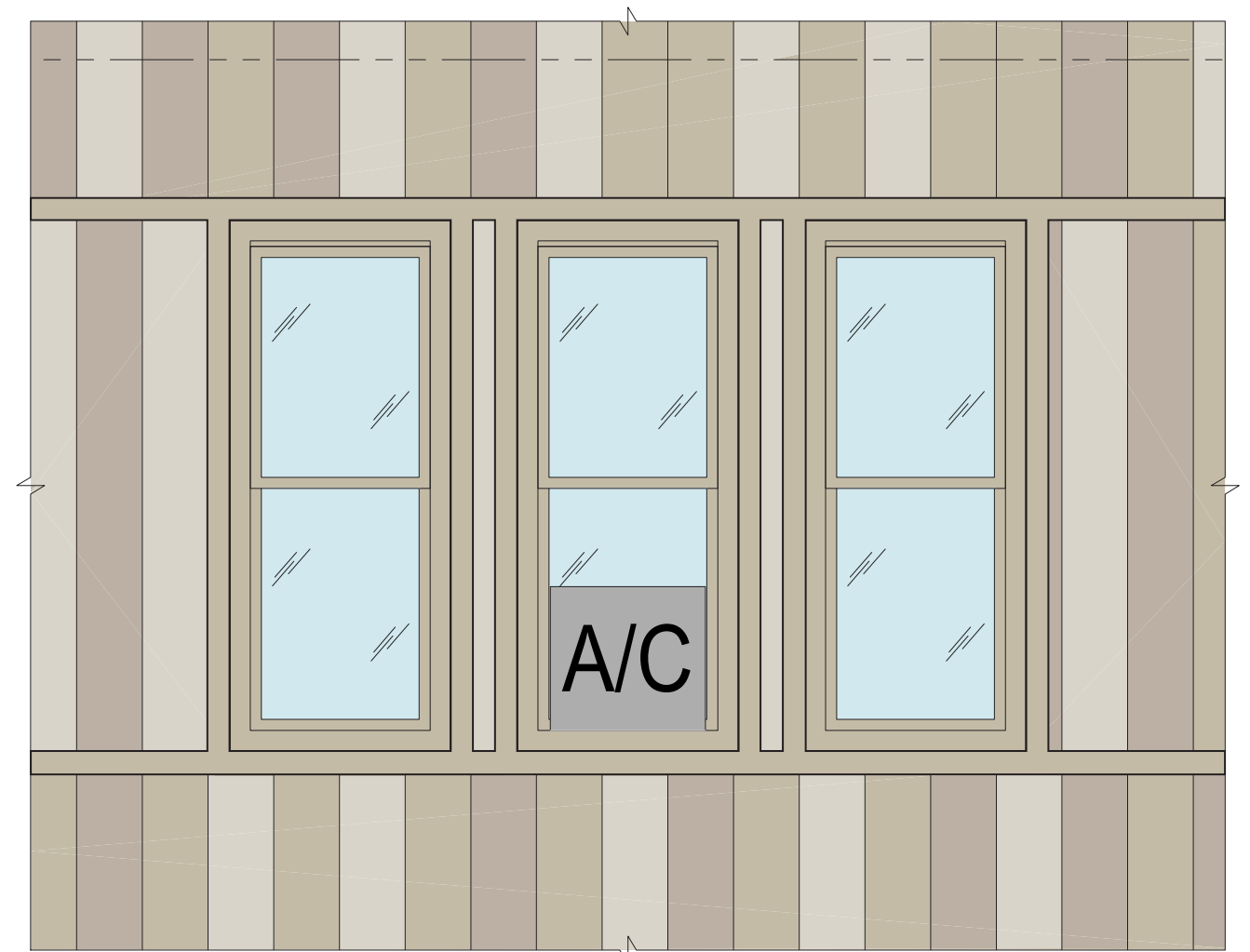

Proposed Windows at Rear Yard Facades

# VISUALIZATIONS

- Replace roofing membrane
- Install PV panels
- Replace coping stones at bulkheads



# MATERIALS - DOORS AND WINDOWS



Dark Bronze at Street Facade  
Windows and Entrance Doors



Light Bronze at Rainscreen Facade  
Windows



Stainless Steel at Ramp Handrails



Bird Friendly Glass



Clear Glass



Ballistic Glass with Opaque film

# MATERIALS - MASONRY AND STONE



Glazed Brick at Street Facade



Common Brick behind Rainscreen Facade



Concrete at Street Facade



Terra Cotta at Street Facade



Limestone at Street Facade



Granite at Street Facade

# MATERIALS - RAINSCREEN



Metal Panel at Rainscreen Facades



1760 Limestone



9911 Pebble



142 Surrey Beige

Metal Panel Color Chart

# CONTACT INFORMATION

- ANNA KILLION**

PHONE: 718 391 1973      MOBILE: 347 374 0930  
 OUTREACH COORDINATOR  
 OFFICE OF COMMUNITY OUTREACH & NOTIFICATION (OCON), DDC  
 KILLIONAN@DDC.NYC.GOV

- NORBERTO ACEVEDO**

PHONE: 718 391 2102      MOBILE: 347 242 9371  
 DIRECTOR  
 OFFICE OF COMMUNITY OUTREACH & NOTIFICATION (OCON), DDC  
 ACEVEDONO@DDC.NYC.GOV

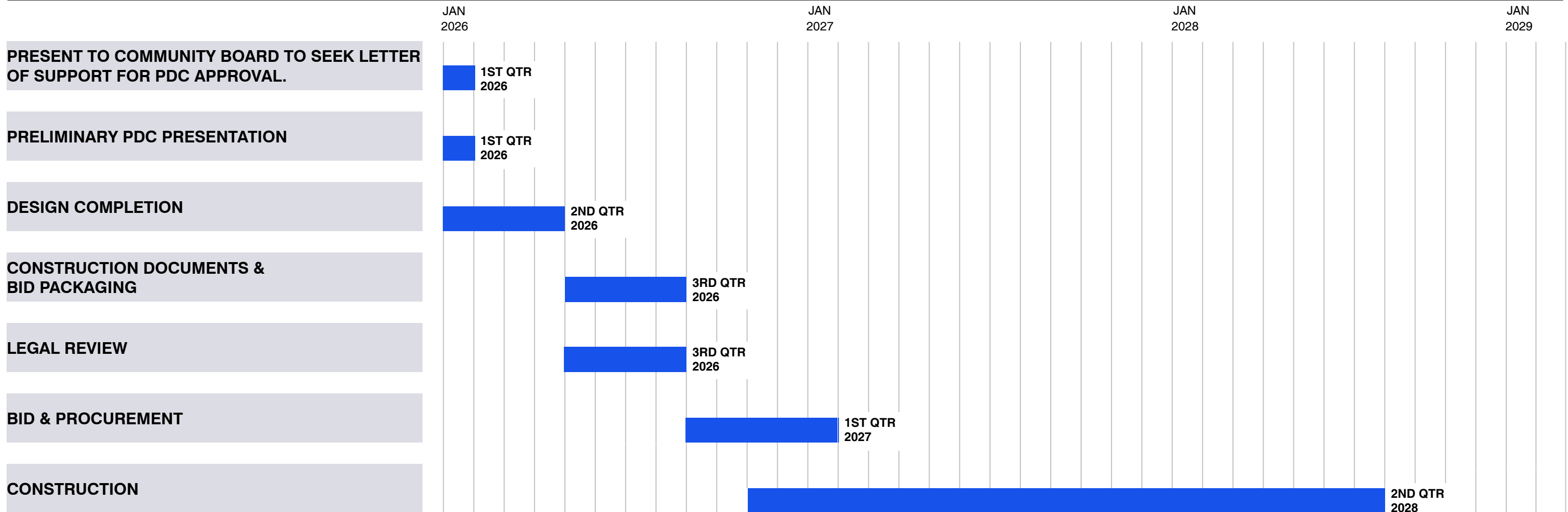

# APPENDIX

# PROPOSED SITE PLAN

- Replace areaway concrete slab and drains
- Repair retaining wall
- Install bike racks
- Install ADA ramp

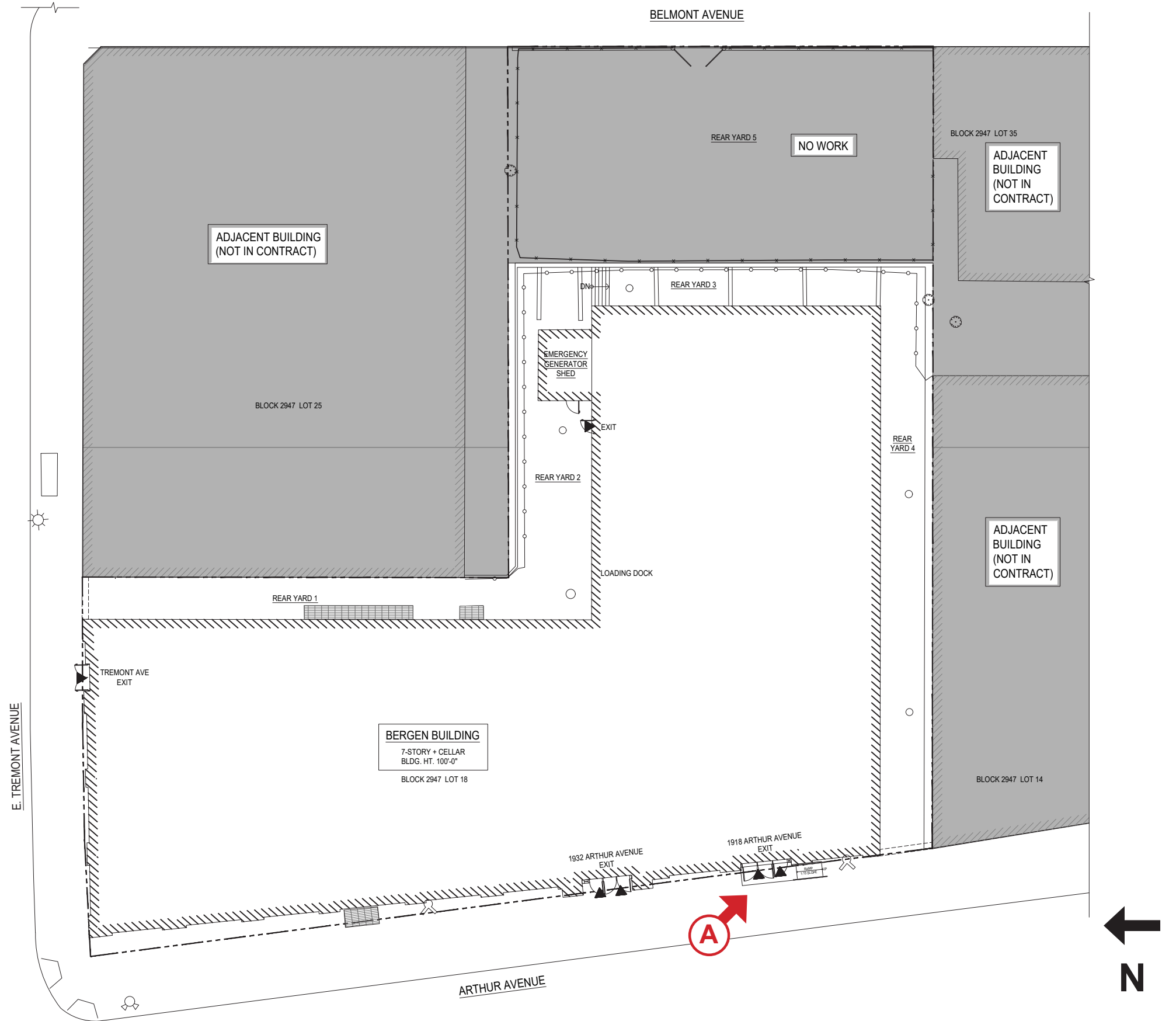

# PROPOSED SITE DETAILS



1 SECTION DETAIL AT EXTERIOR RAMP  
1918 ARTHUR AVE  
SCALE: 1-1/2" = 1'-0"

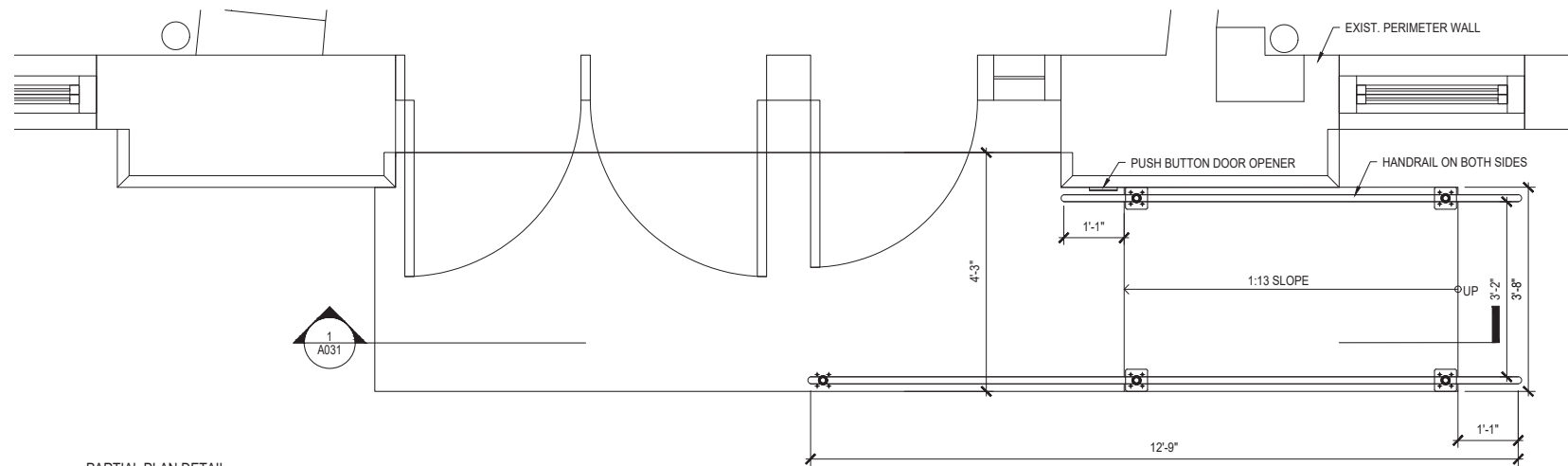

2 PARTIAL PLAN DETAIL AT EXTERIOR RAMP  
SCALE: 3/4" = 1'-0"

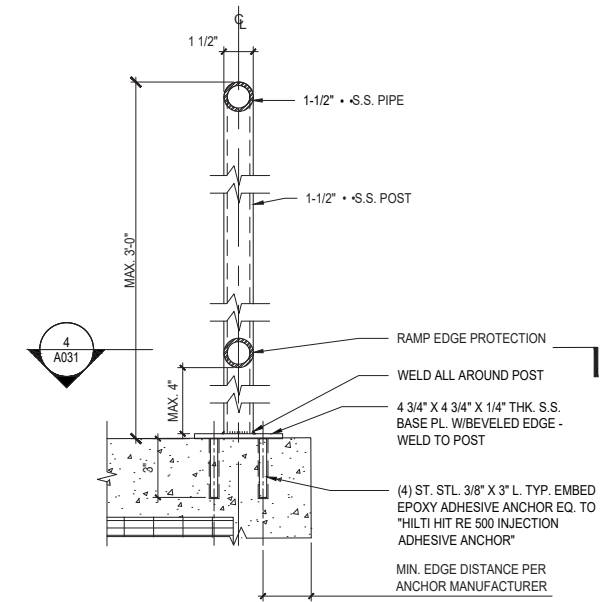

3 SECTION DETAIL AT EXTERIOR RAMP  
HANDRAIL POST  
SCALE: 3" = 1'-0"

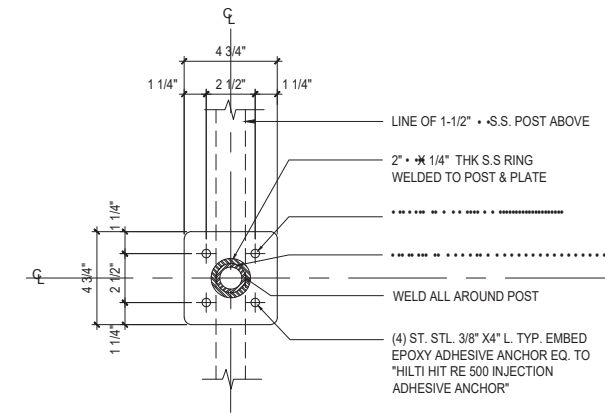

4 SECTION DETAIL AT EXTERIOR RAMP  
HANDRAIL BASE PLATE  
SCALE: 3" = 1'-0"



# EXISTING PLANS

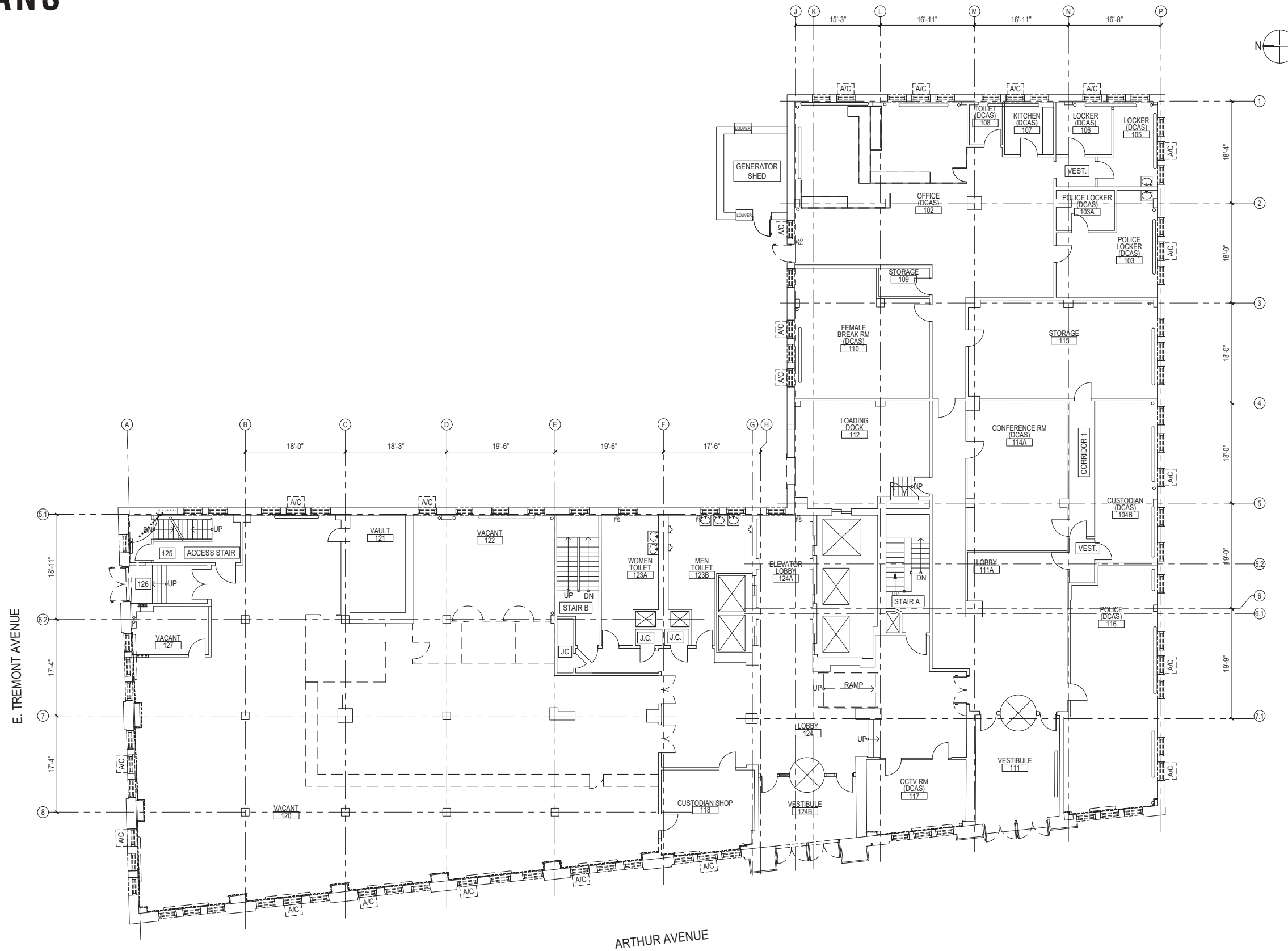

# PROPOSED PLANS

- Replace windows
- Glazed brick, stone and concrete repair
- Replace entrance doors
- Install ADA ramp at 1918 Arthur Ave entrance
- Replace roll-up door

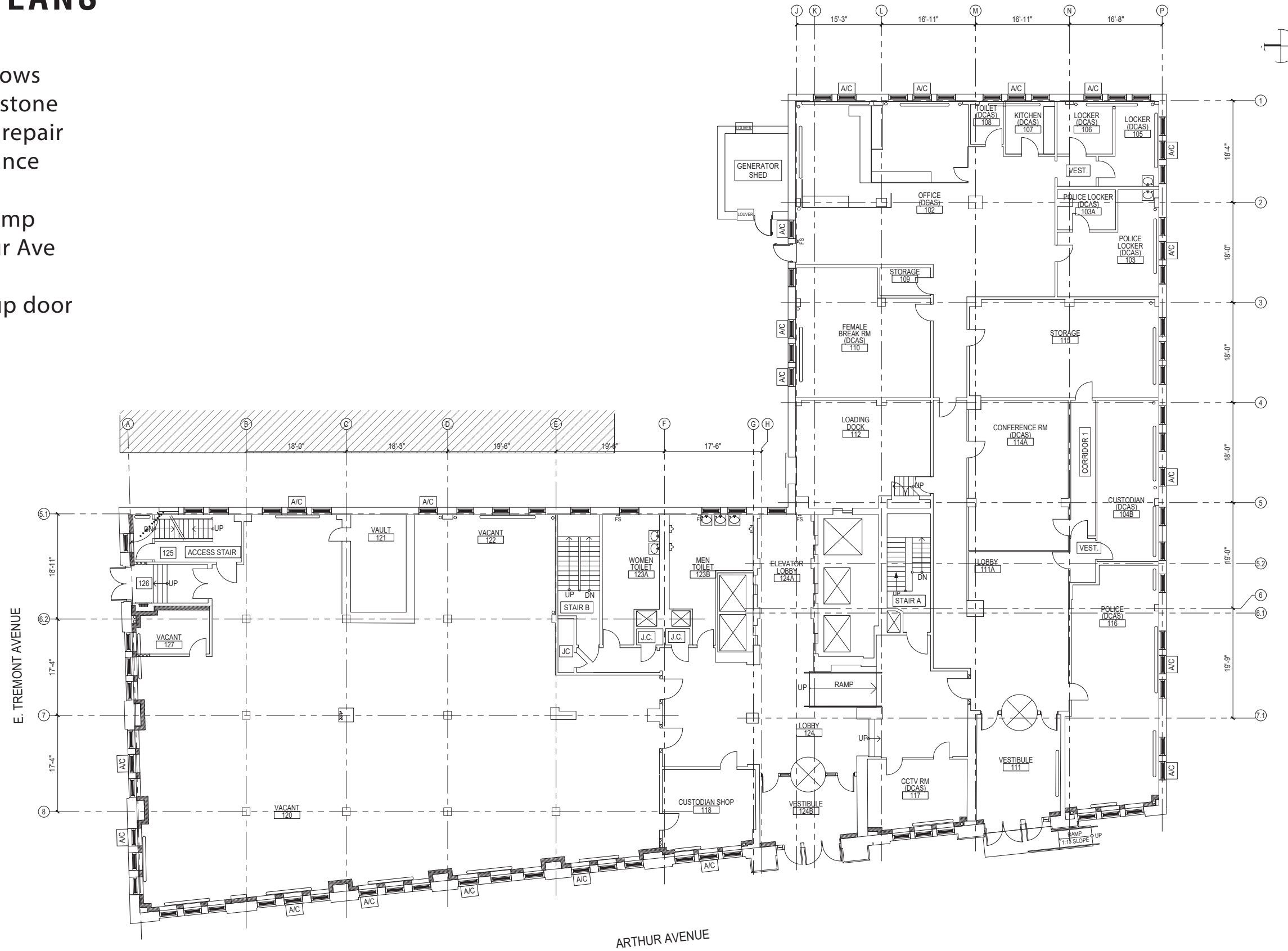

# EXISTING PLANS

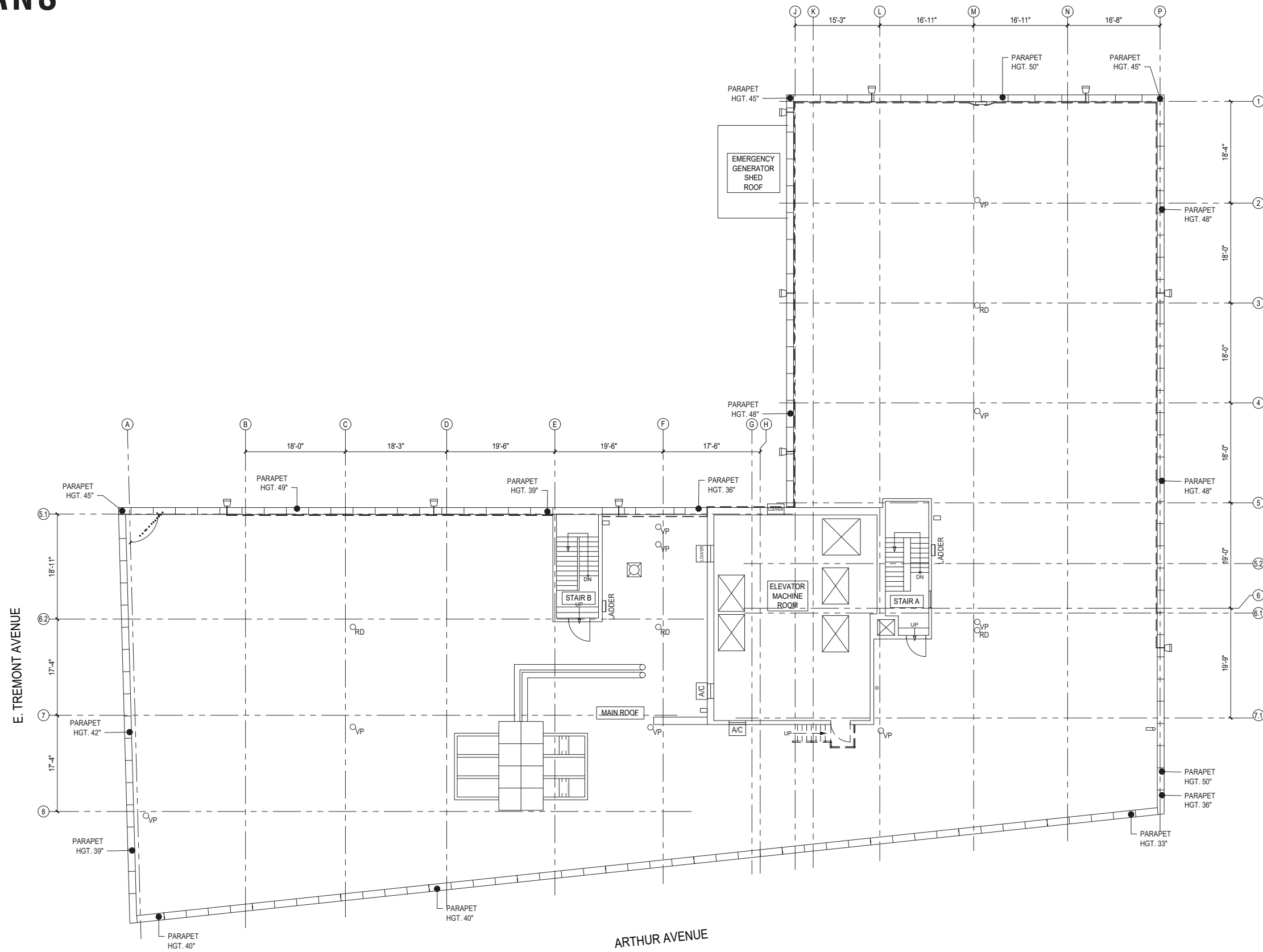

# PROPOSED PLANS

- Replace roofing membrane
- Install PV panels
- Replace coping stones at bulkheads
- Replace doors and windows
- Install rainscreen
- Replace steel ladders

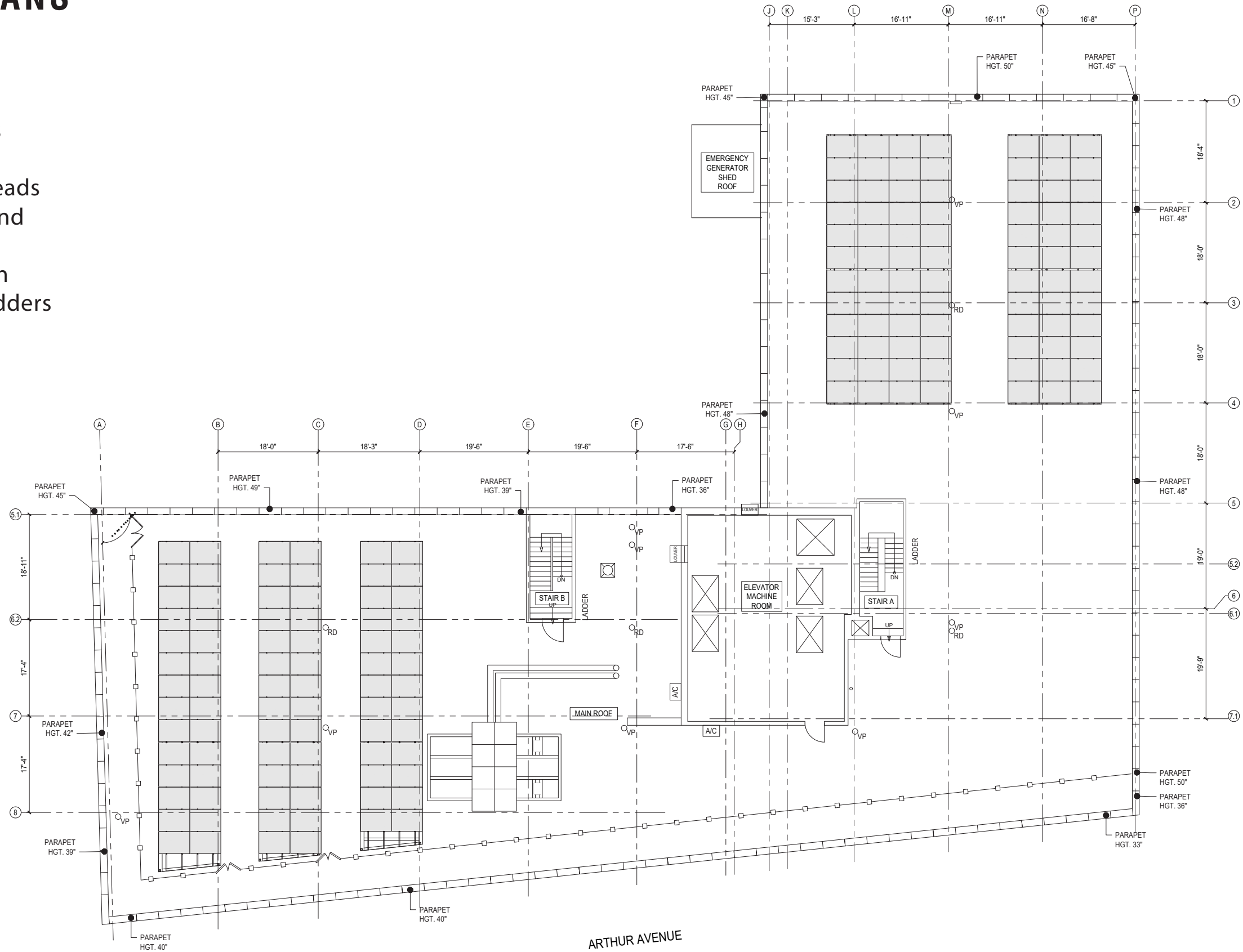

# EXISTING PLANS

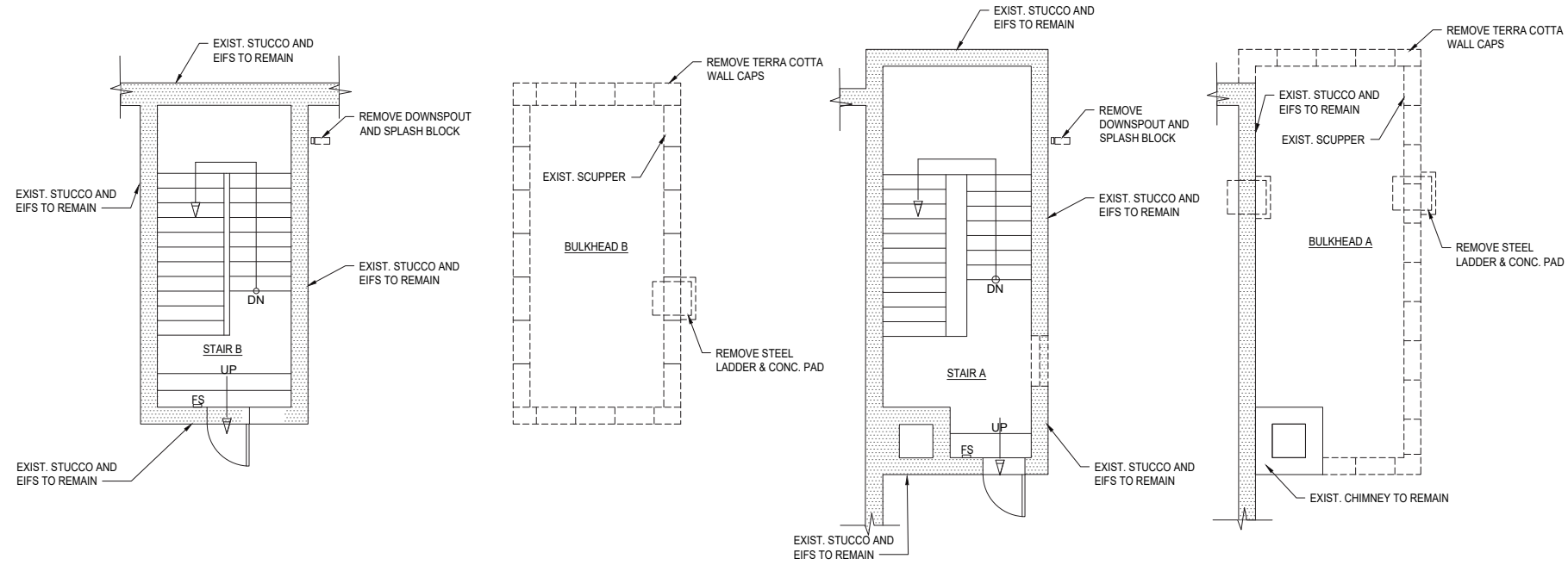

1 ENLARGED FLOOR PLAN AT BULKHEAD B  
SCALE: 1/4" = 1'-0"

2 ENLARGED ROOF PLAN AT BULKHEAD B  
SCALE: 1/4" = 1'-0"

3 ENLARGED FLOOR PLAN AT BULKHEAD A  
SCALE: 1/4" = 1'-0"

4 ENLARGED ROOF PLAN AT BULKHEAD A  
SCALE: 1/4" = 1'-0"

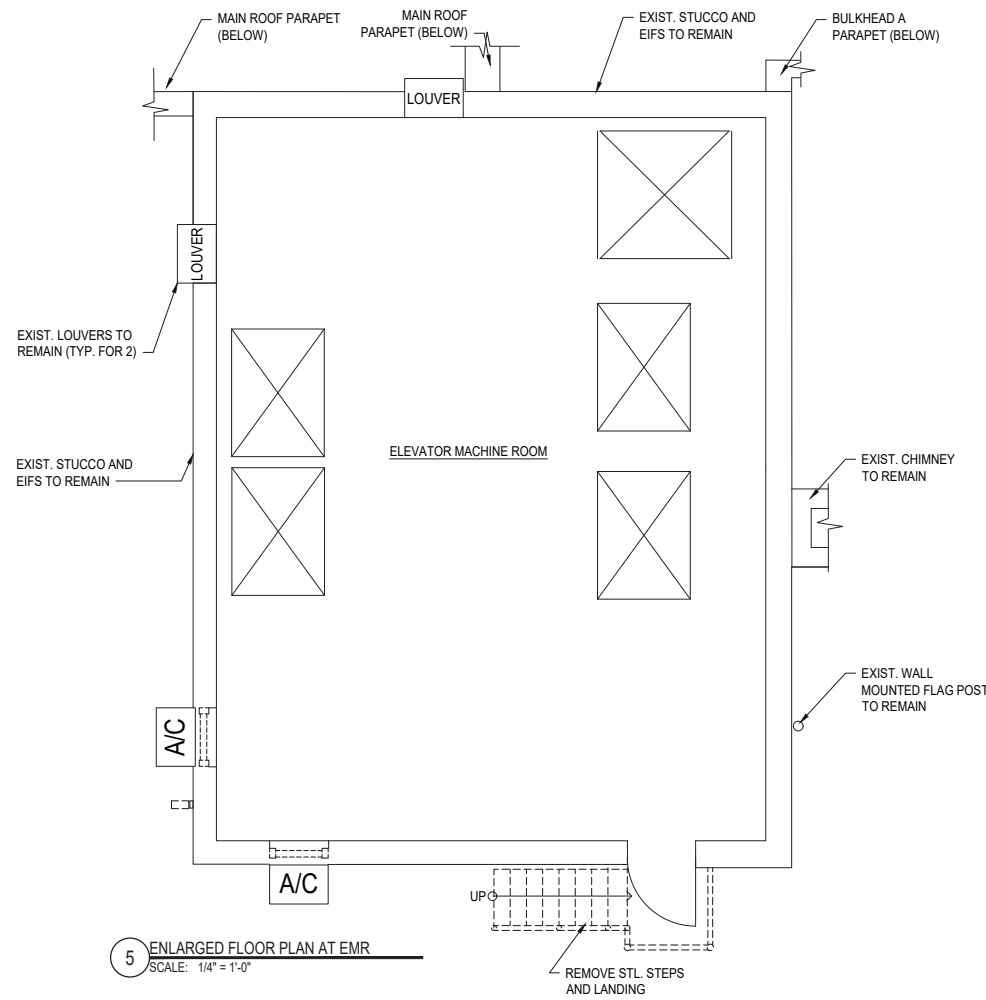

5 ENLARGED FLOOR PLAN AT EMR  
SCALE: 1/4" = 1'-0"

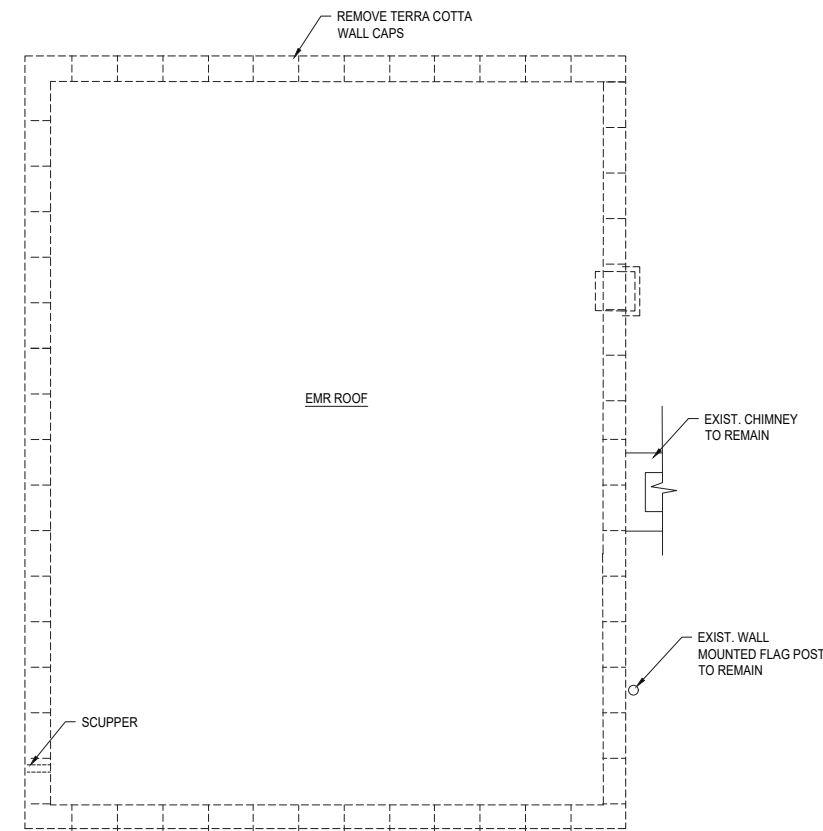

6 ENLARGED ROOF PLAN AT EMR  
SCALE: 1/4" = 1'-0"



# PROPOSED PLANS

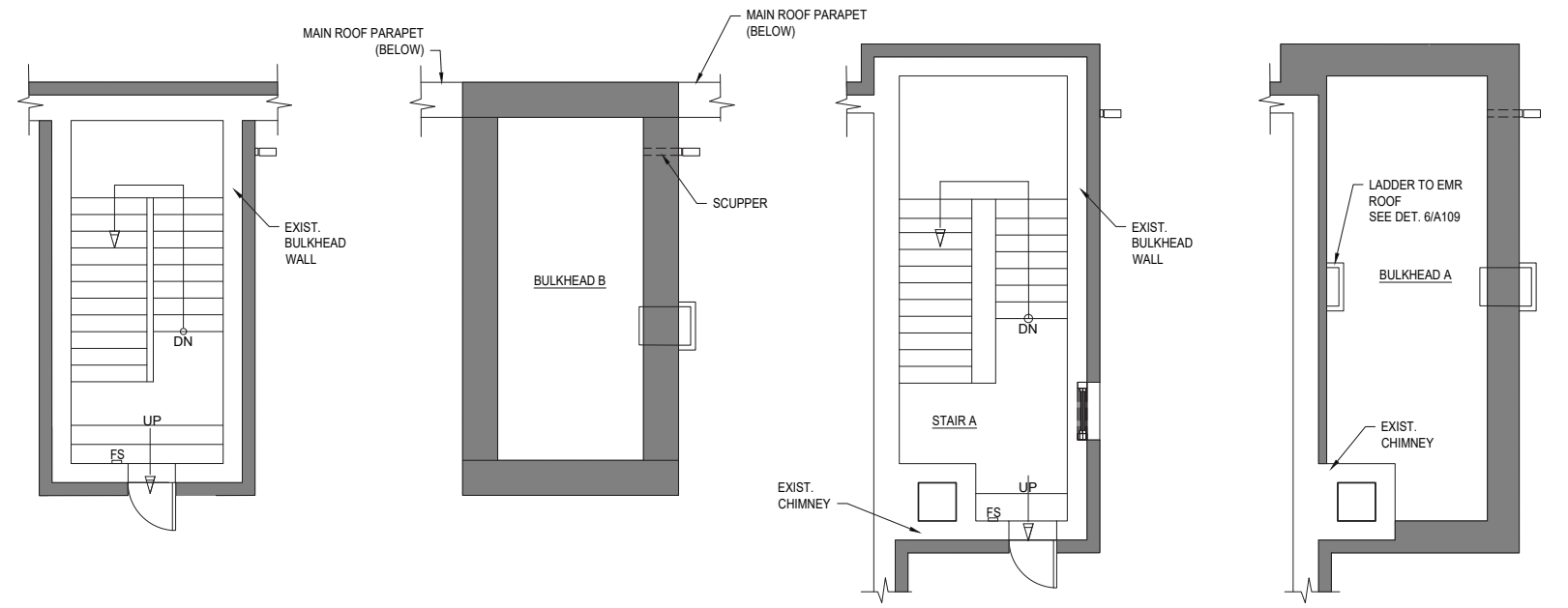

1 ENLARGED FLOOR PLAN AT BULKHEAD B  
SCALE: 1/4" = 1'-0"

2 ENLARGED ROOF PLAN AT BULKHEAD B  
SCALE: 1/4" = 1'-0"

3 ENLARGED FLOOR PLAN AT BULKHEAD A  
SCALE: 1/4" = 1'-0"

4 ENLARGED ROOF PLAN AT BULKHEAD A  
SCALE: 1/4" = 1'-0"

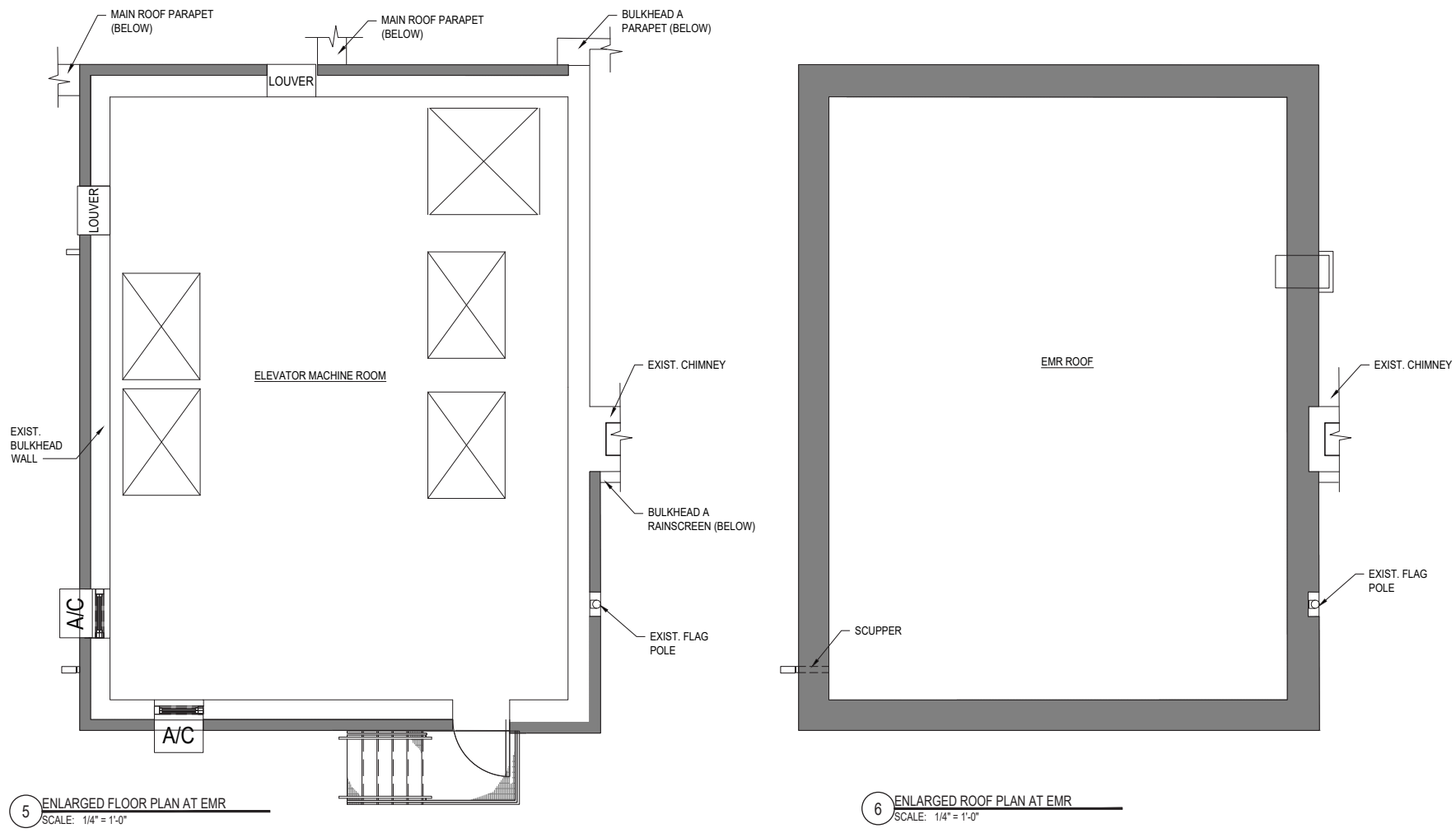

5 ENLARGED FLOOR PLAN AT EMR  
SCALE: 1/4" = 1'-0"

6 ENLARGED ROOF PLAN AT EMR  
SCALE: 1/4" = 1'-0"



# EXISTING ELEVATIONS

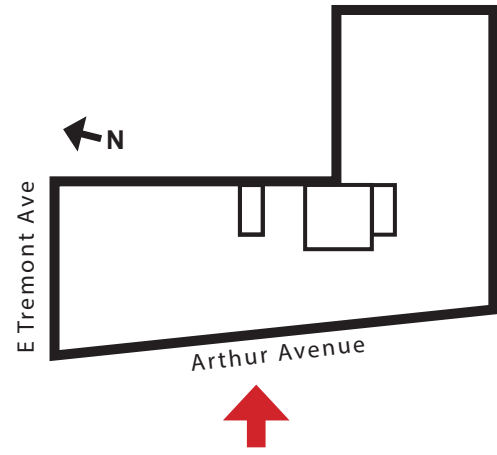

# PROPOSED ELEVATIONS

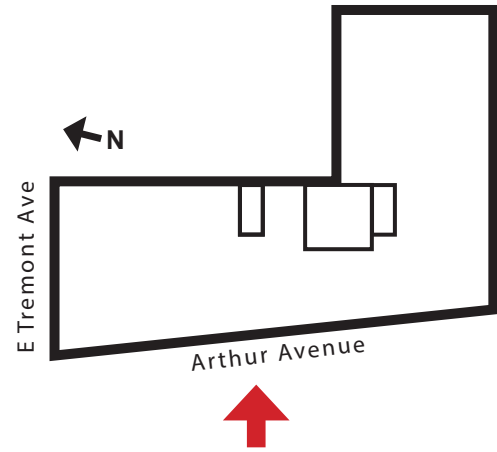

- Replace windows
- Glazed brick, stone and concrete repair
- Replace entrance doors
- Install ADA ramp at 1918 Arthur Ave entrance
- Replace roll-up security door



# EXISTING ELEVATIONS

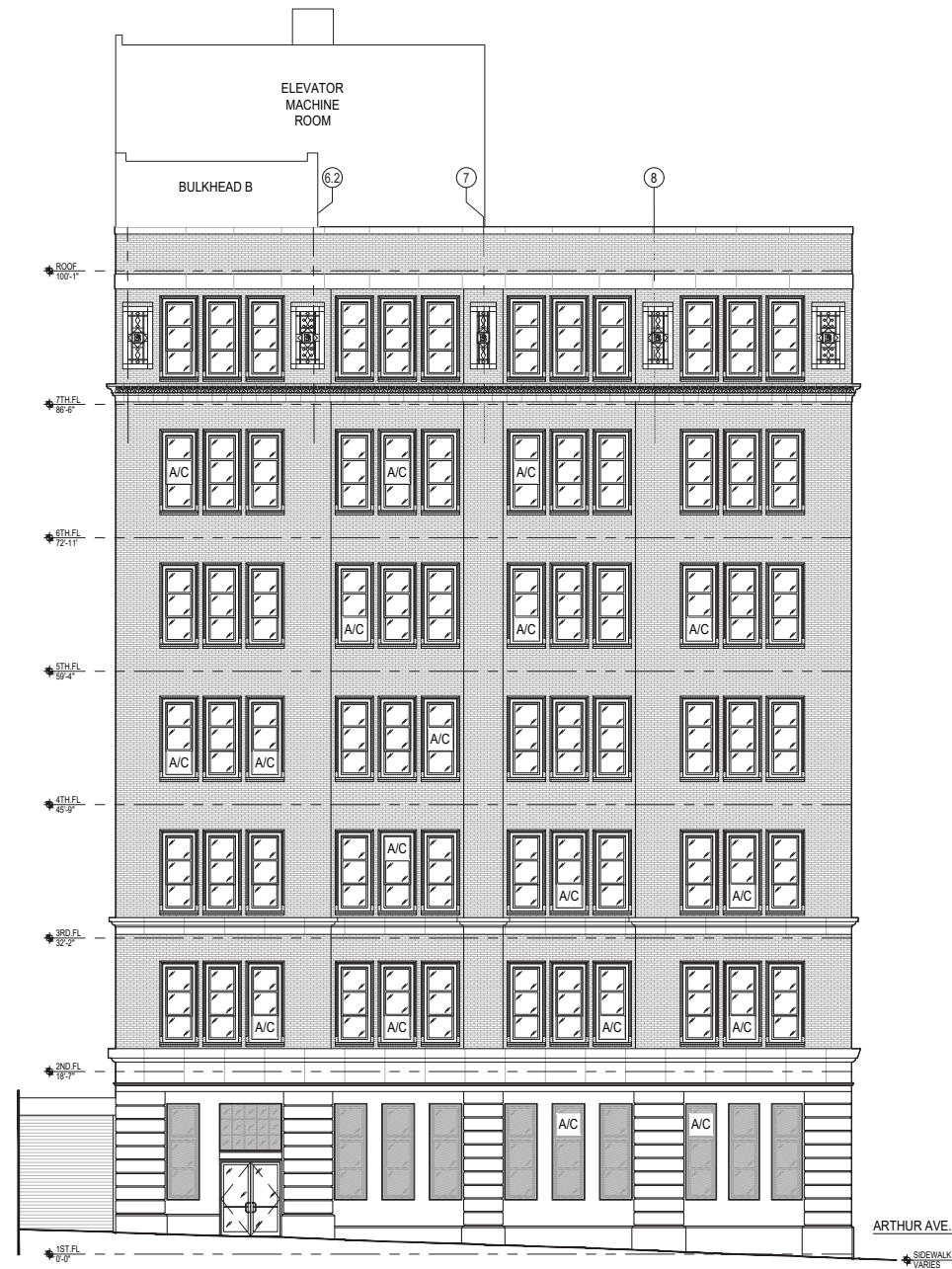
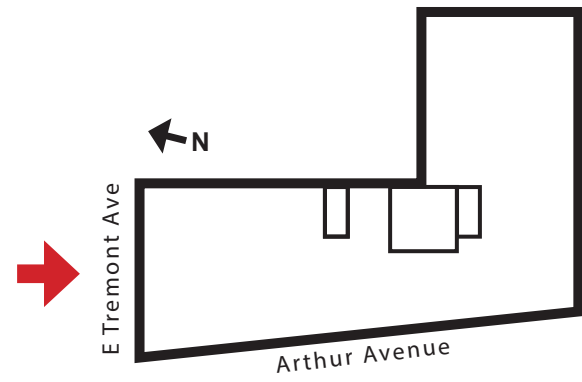

# PROPOSED ELEVATIONS

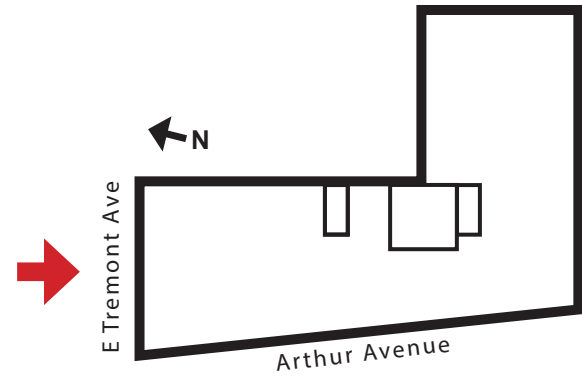

- Replace windows
- Glazed brick, stone and concrete repair
- Replace entrance door
- Replace roll-up security door

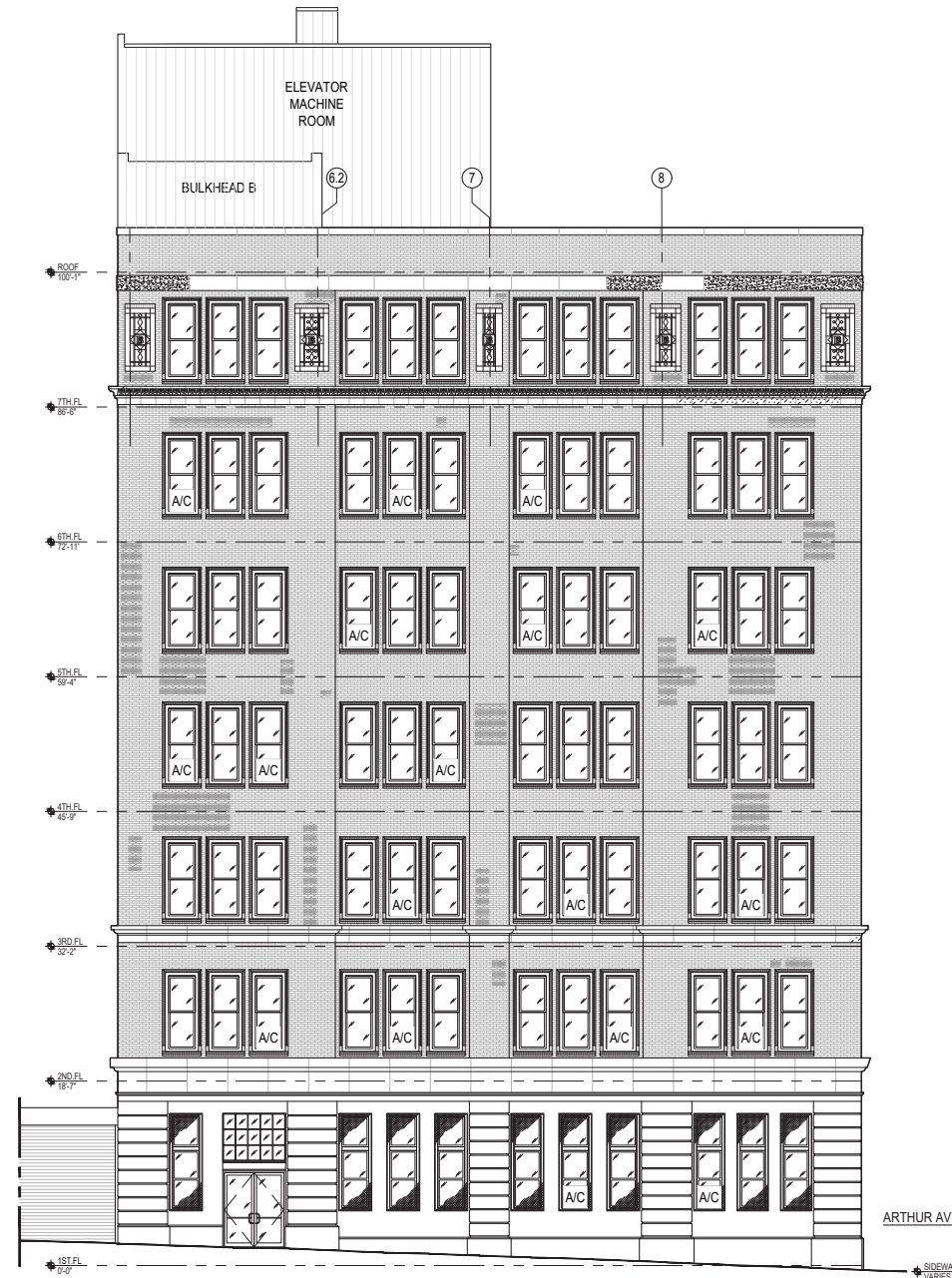

# EXISTING ELEVATIONS

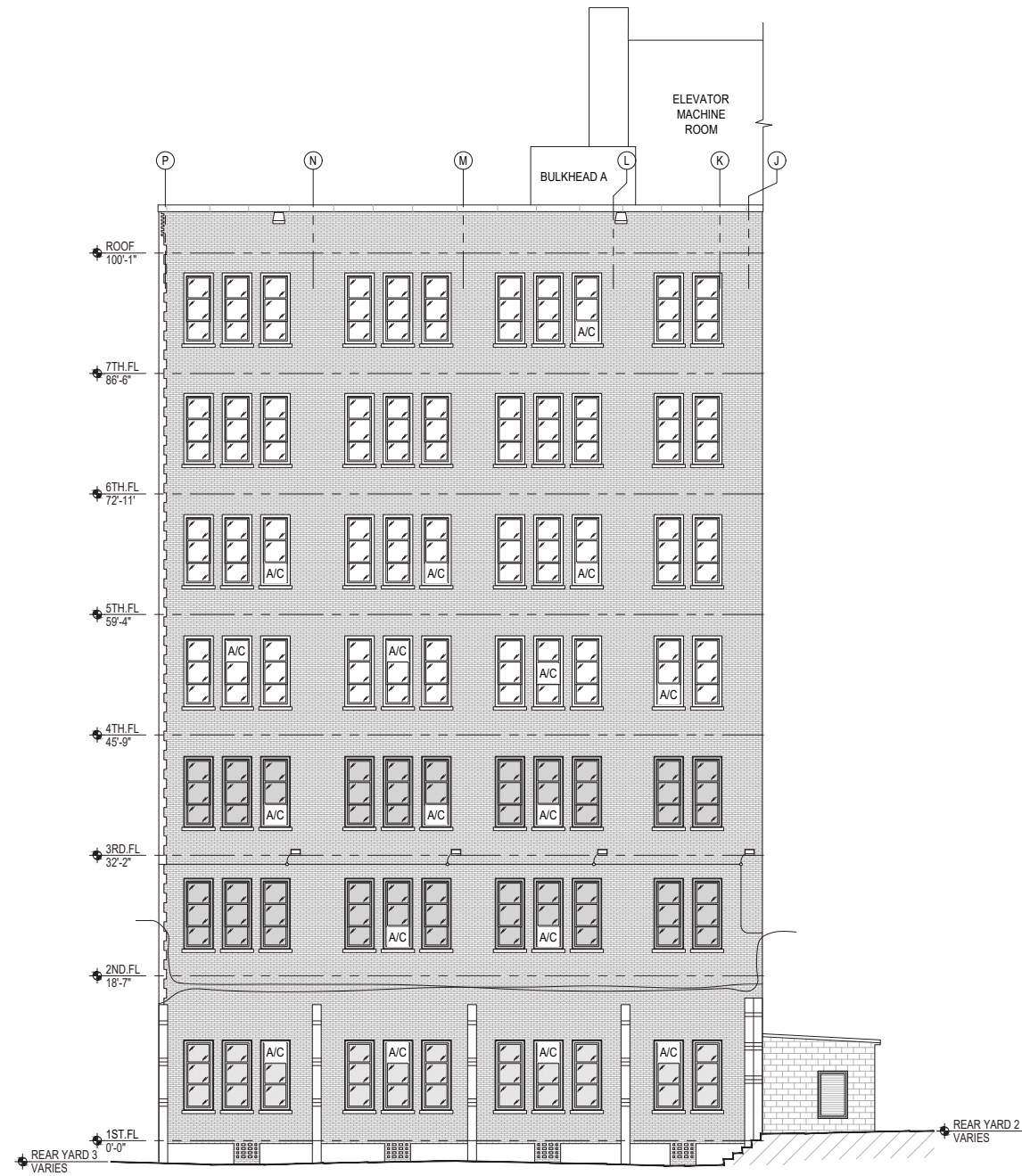
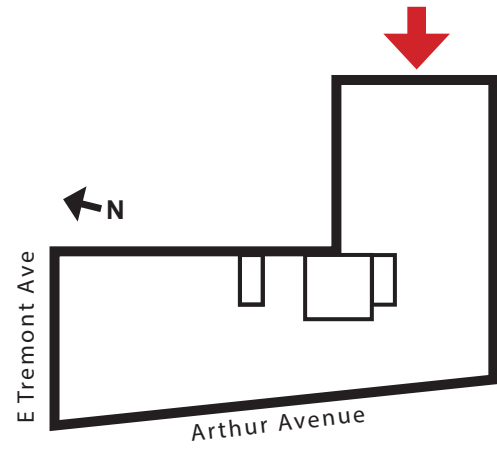

# PROPOSED ELEVATIONS

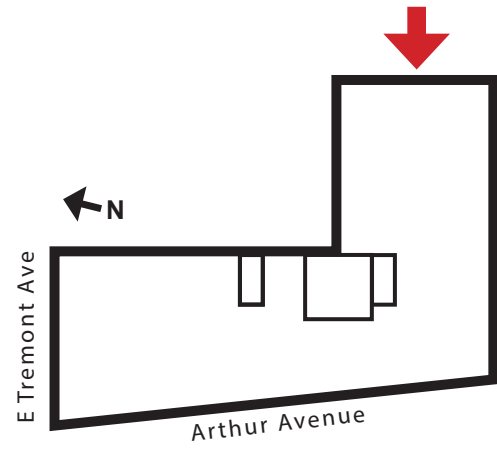

- Replace windows
- Install rainscreen

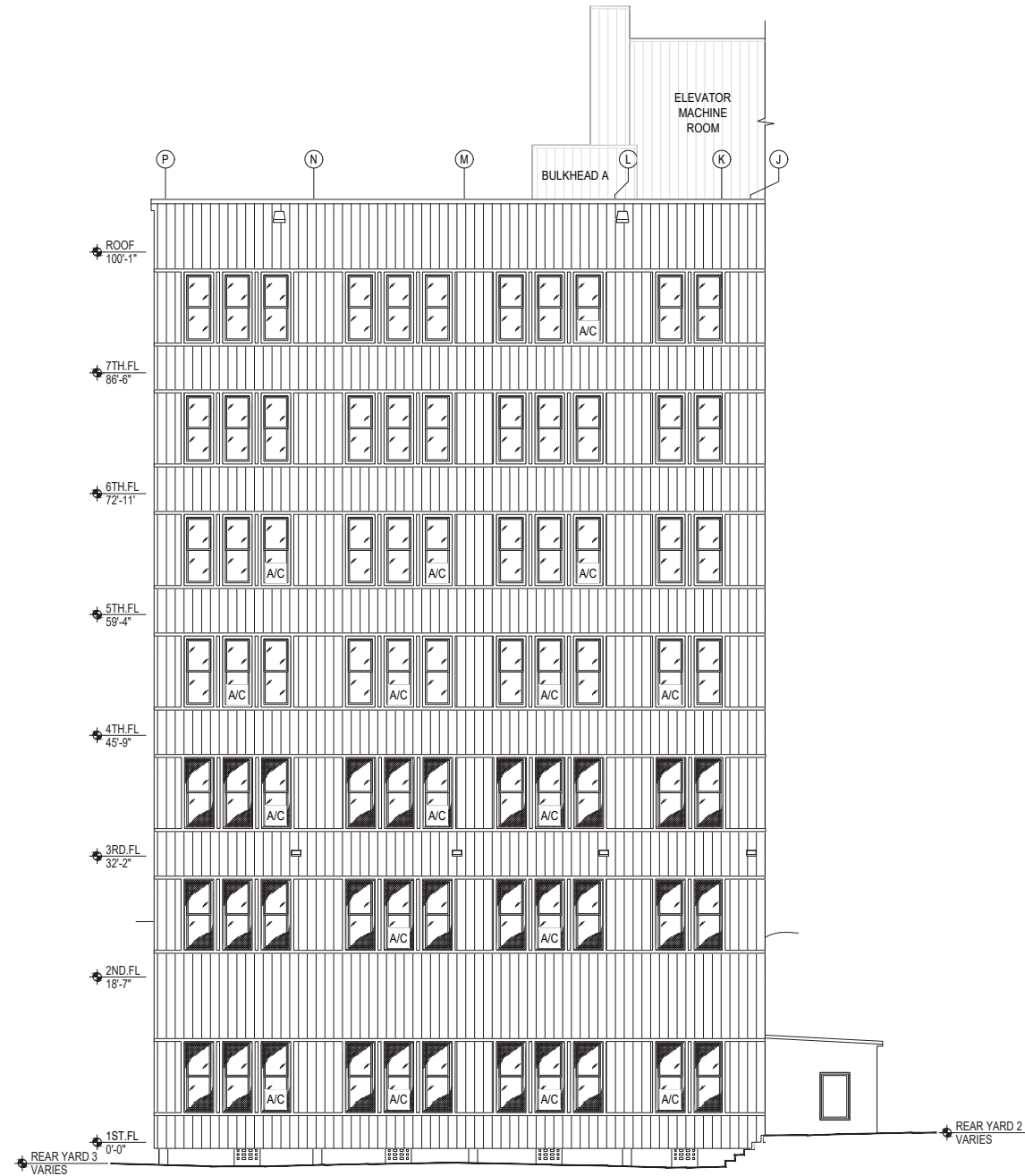

# EXISTING ELEVATIONS

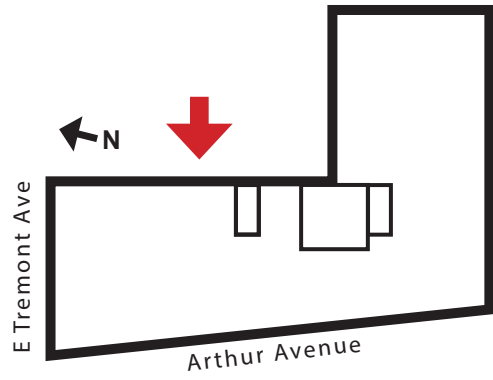

# PROPOSED ELEVATIONS

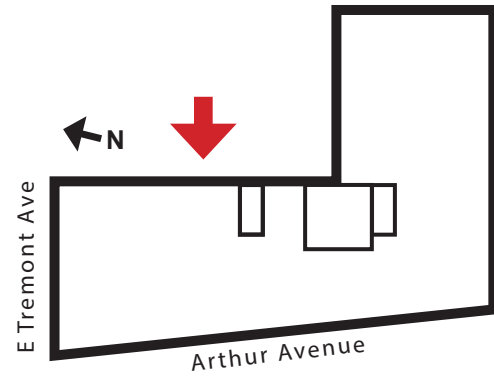

- Replace windows
- Install rainscreen



# EXISTING ELEVATIONS

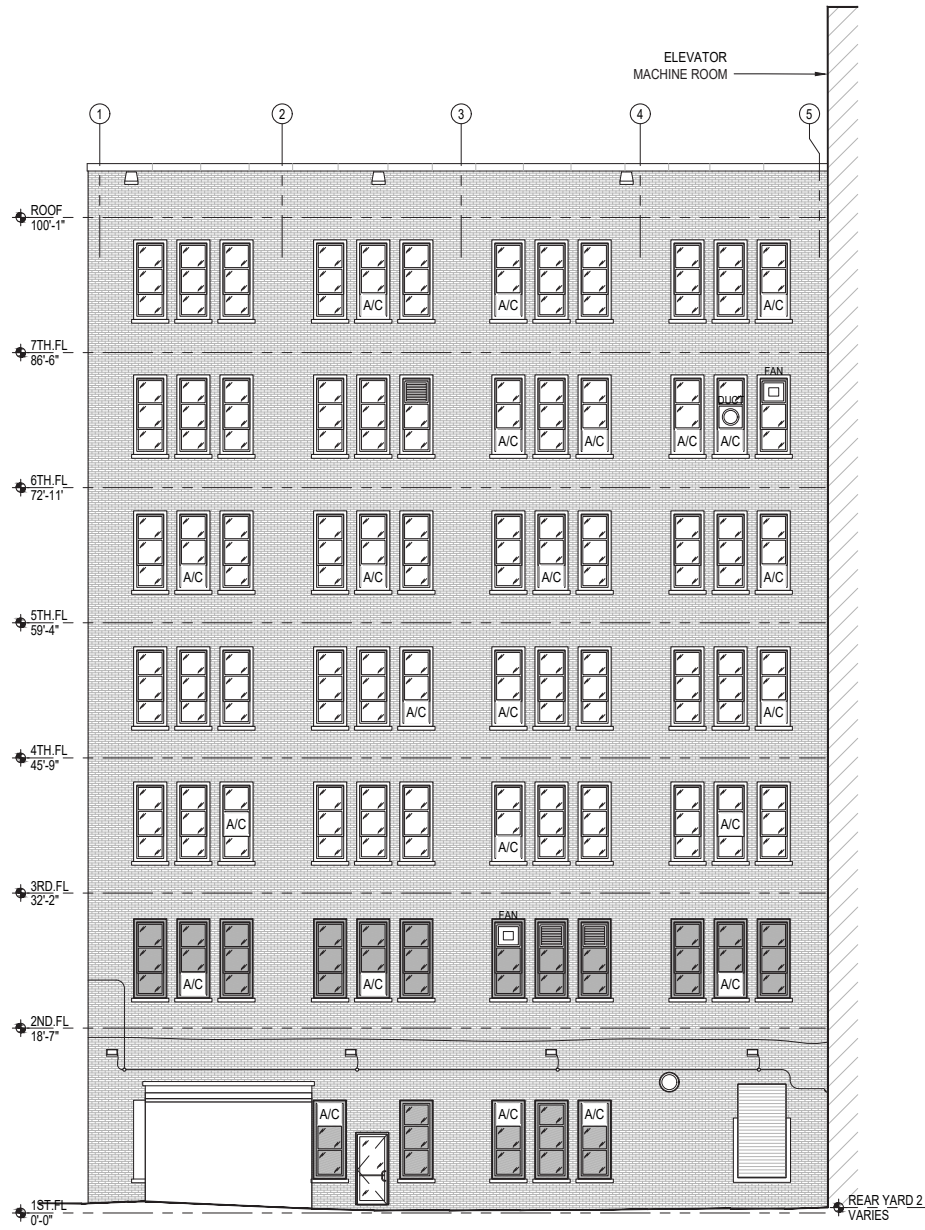
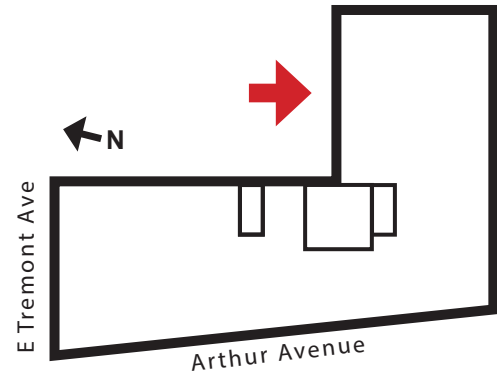

# PROPOSED ELEVATIONS

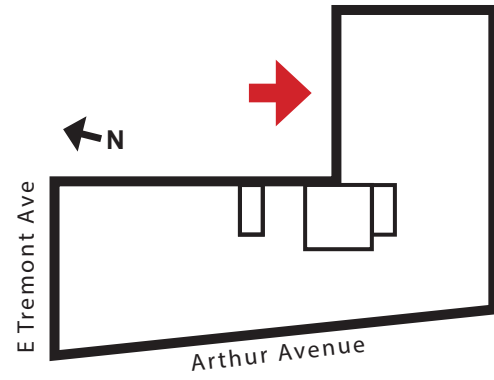

- Replace windows
- Install rainscreen

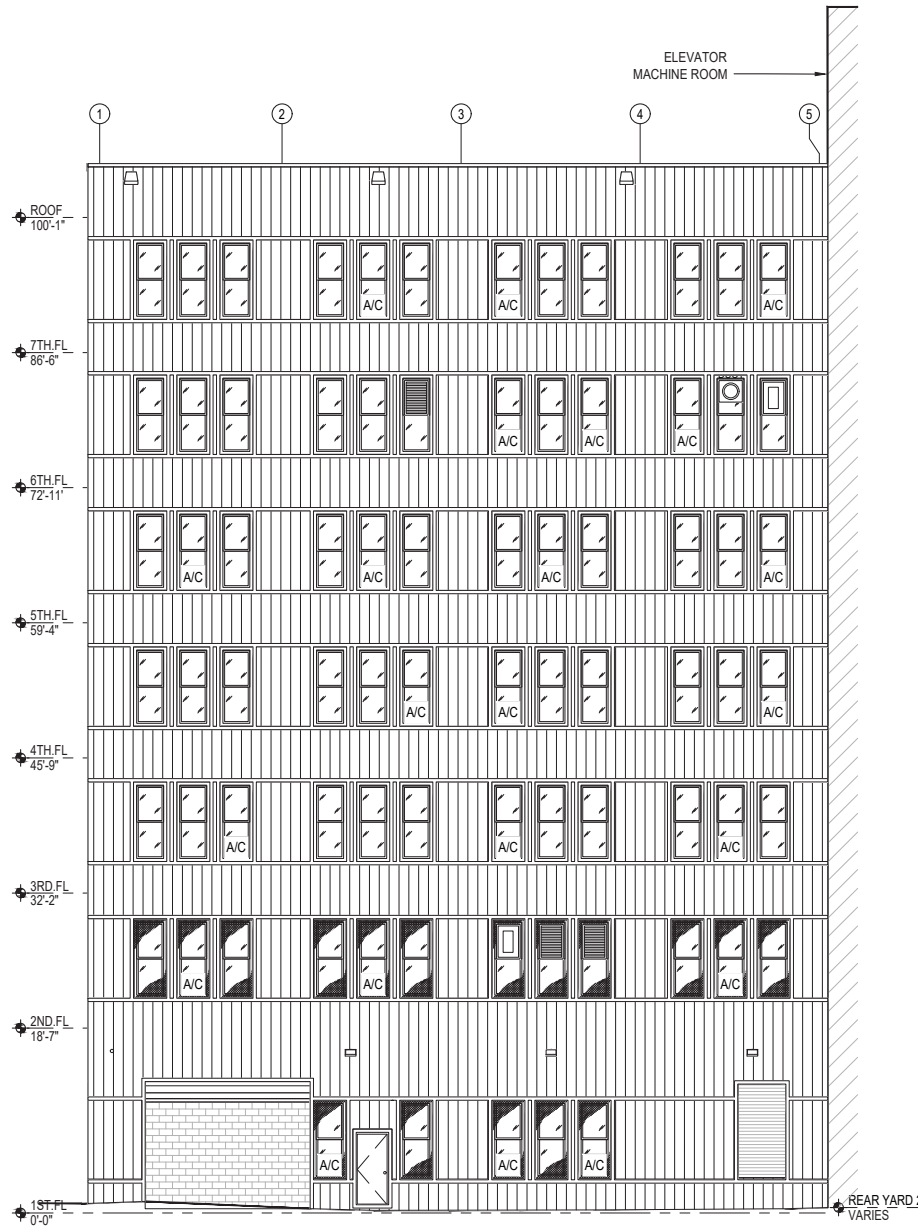

# EXISTING ELEVATIONS

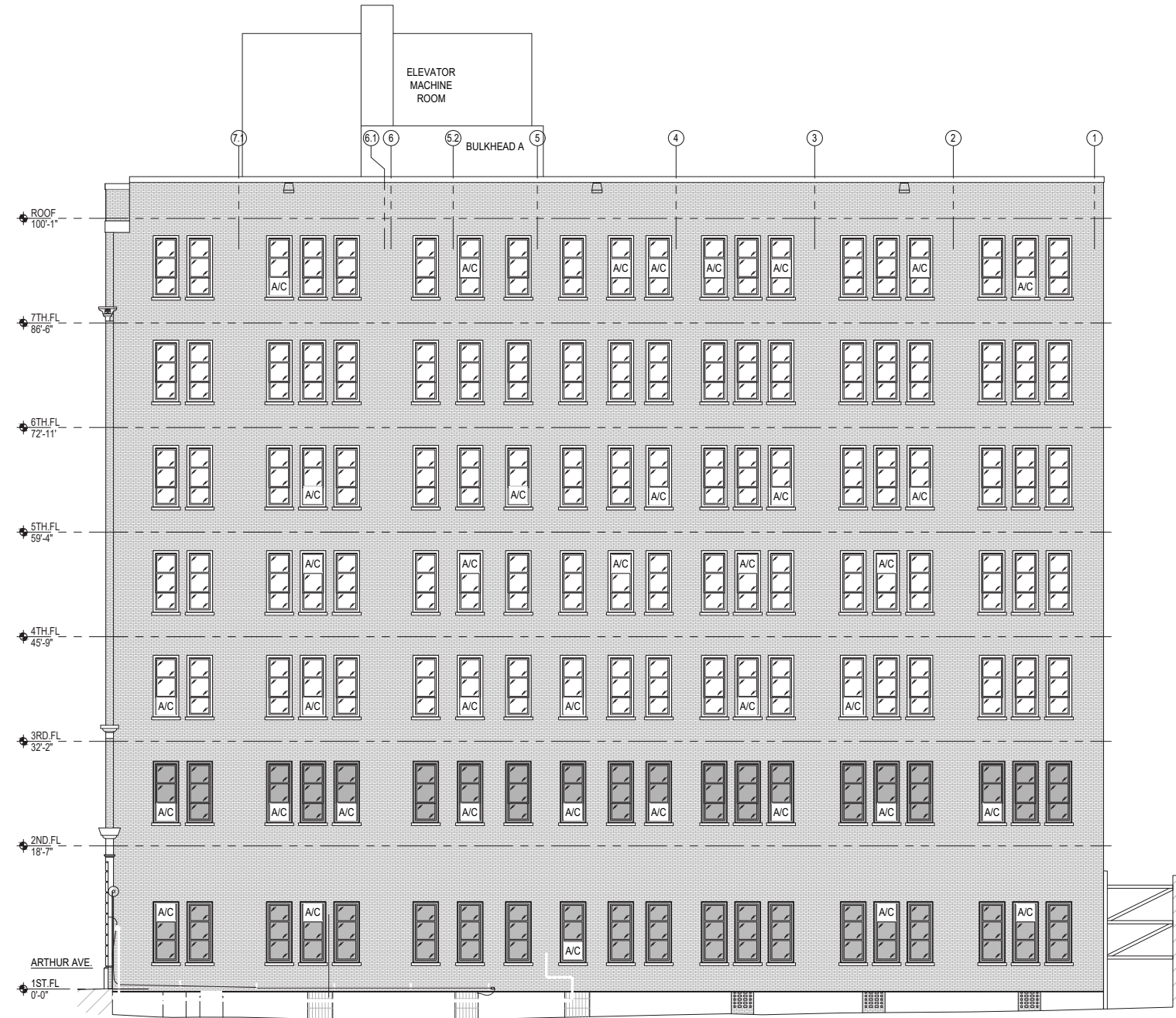
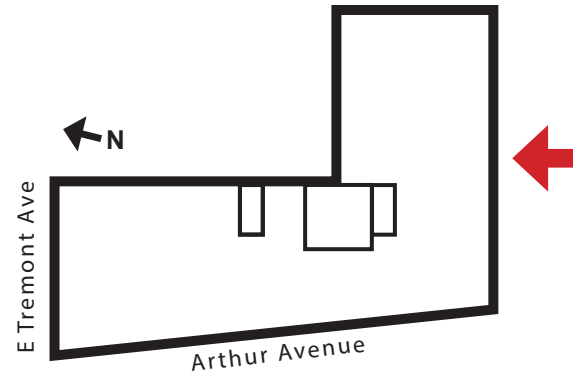

# PROPOSED ELEVATIONS

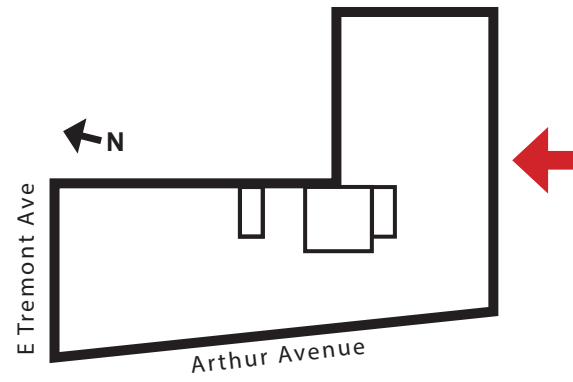

- Replace windows
- Install rainscreen

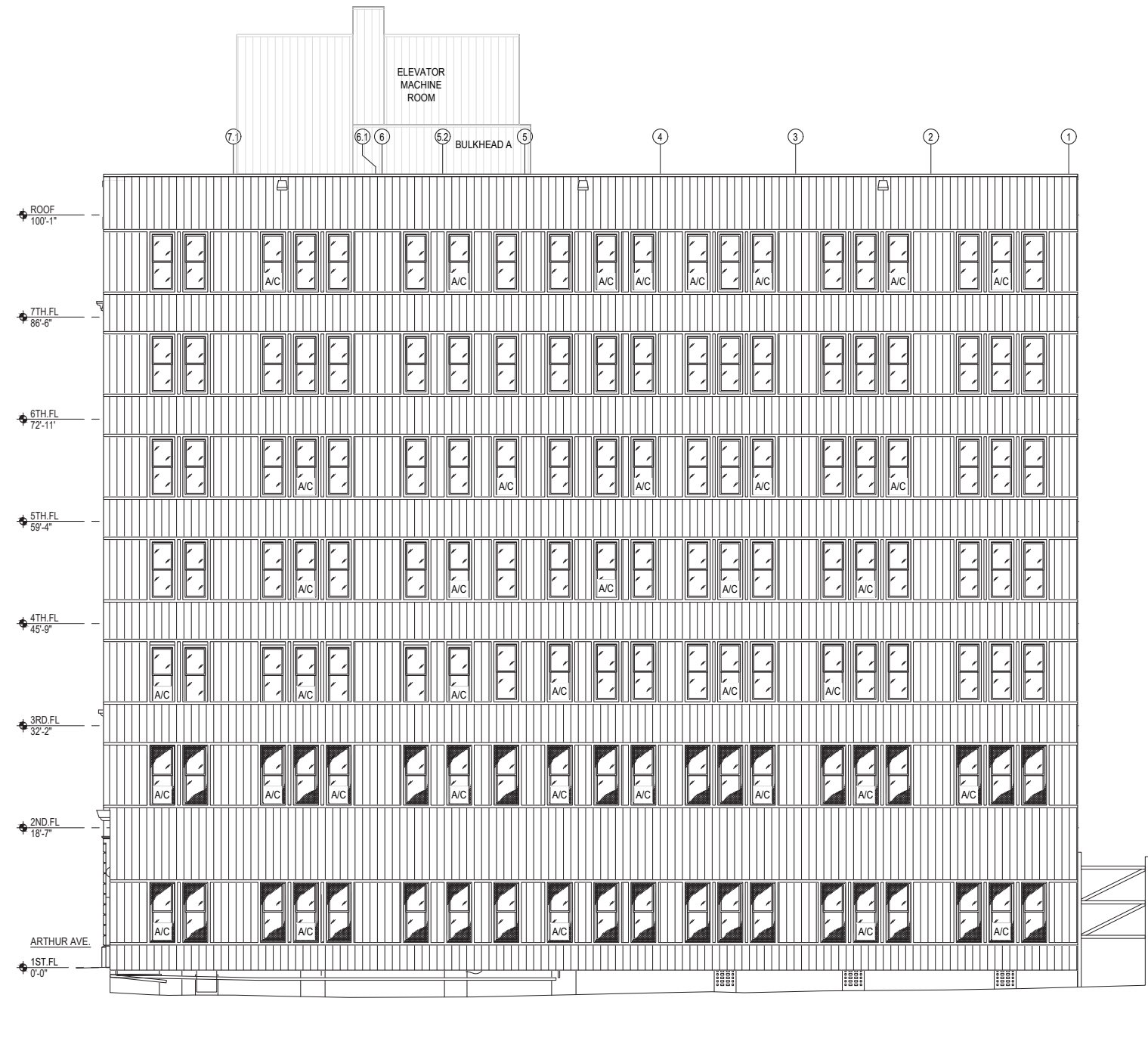

# EXISTING ELEVATIONS

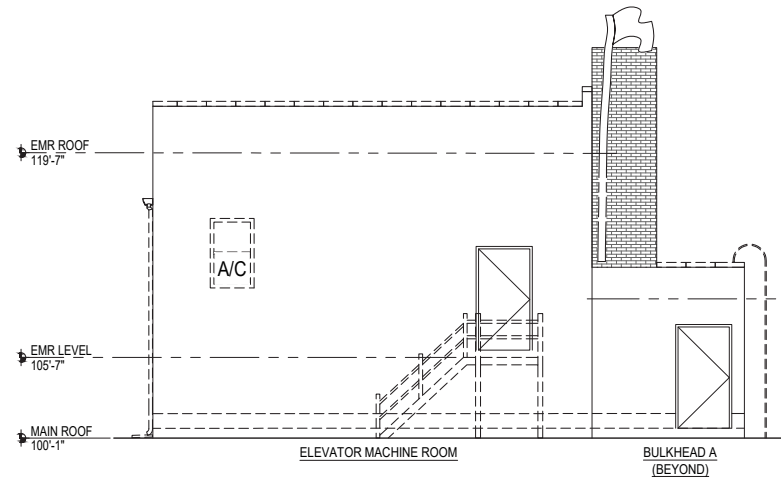

1 WEST ELEVATION  
AT EMR & BULKHEAD A  
SCALE: 3/16" = 1'-0"

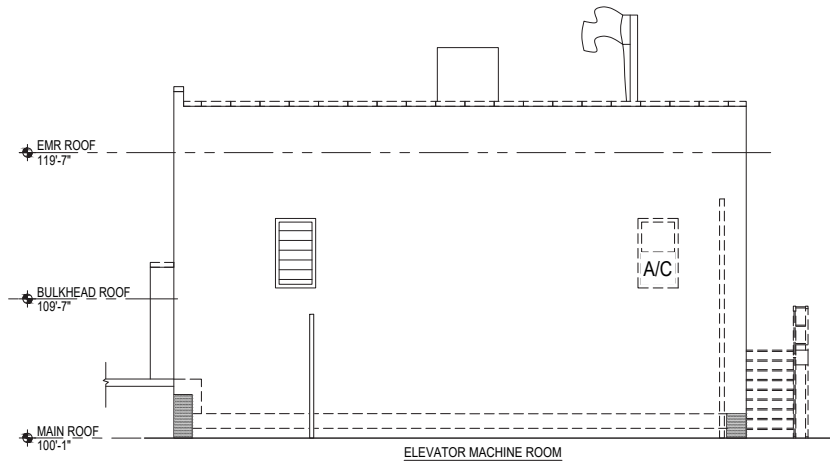

2 NORTH ELEVATION  
AT EMR & BULKHEAD A  
SCALE: 3/16" = 1'-0"

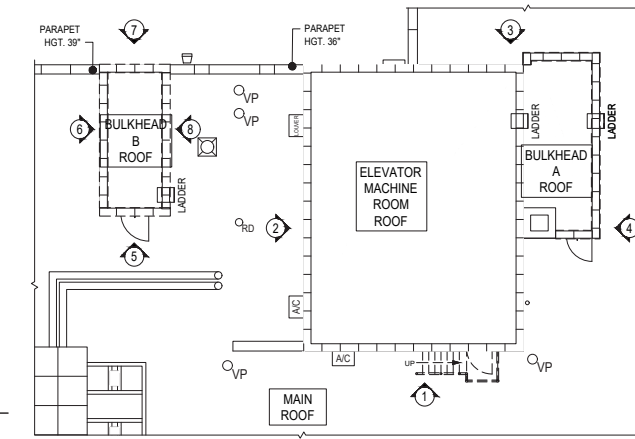

A PARTIAL ROOF PLAN AT BULKHEAD &  
ELEVATOR MACHINE ROOM  
SCALE: 3/32" = 1'-0"

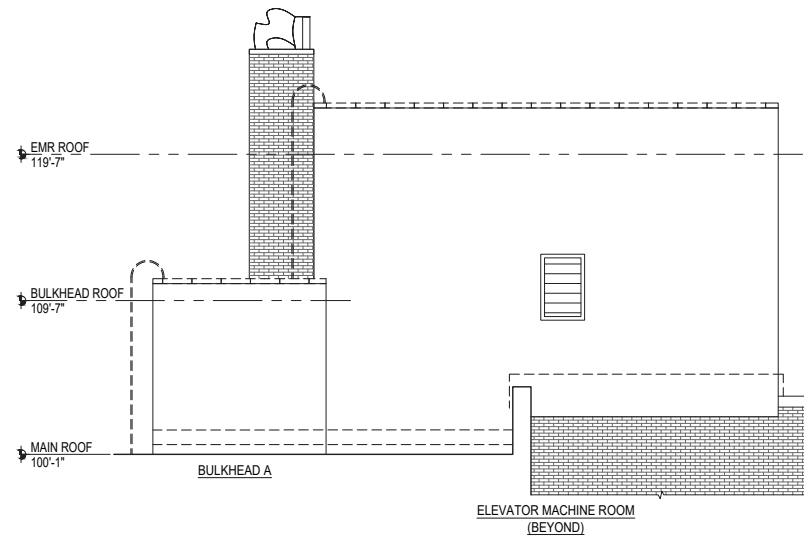

3 EAST ELEVATION  
AT EMR & BULKHEAD A  
SCALE: 3/16" = 1'-0"

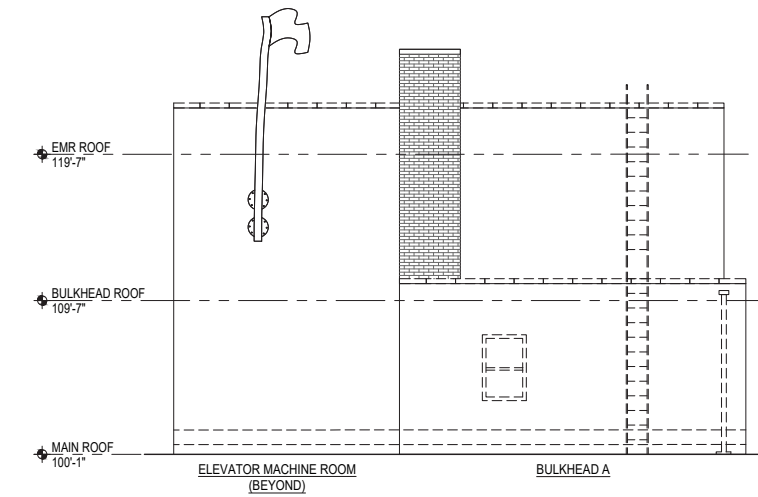

4 SOUTH ELEVATION  
AT EMR & BULKHEAD A  
SCALE: 3/16" = 1'-0"

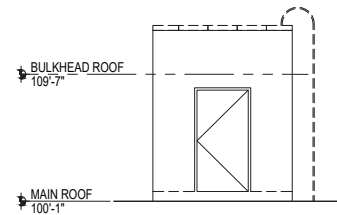

5 WEST ELEVATION  
AT BULKHEAD B  
SCALE: 3/16" = 1'-0"

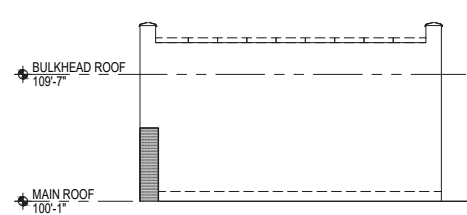

6 NORTH ELEVATION  
AT BULKHEAD B  
SCALE: 3/16" = 1'-0"

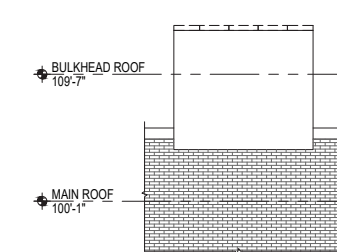

7 EAST ELEVATION  
AT BULKHEAD B  
SCALE: 3/16" = 1'-0"

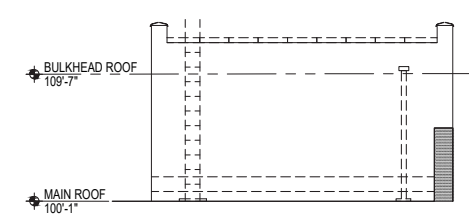

8 SOUTH ELEVATION  
AT BULKHEAD B  
SCALE: 3/16" = 1'-0"



# PROPOSED ELEVATIONS

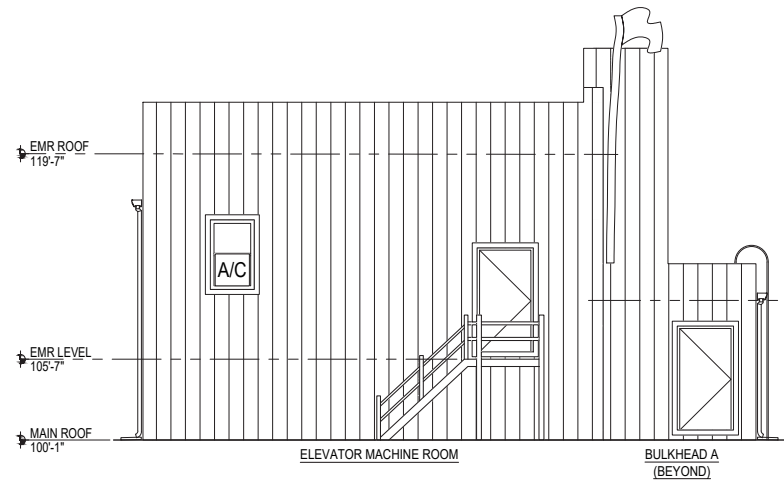

1 WEST ELEVATION  
AT EMR & BULKHEAD A  
SCALE: 3/16" = 1'-0"

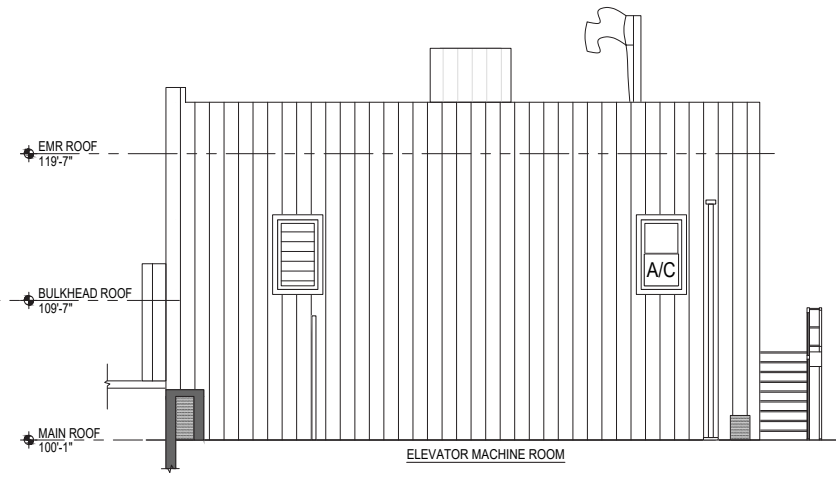

2 NORTH ELEVATION  
AT EMR & BULKHEAD A  
SCALE: 3/16" = 1'-0"

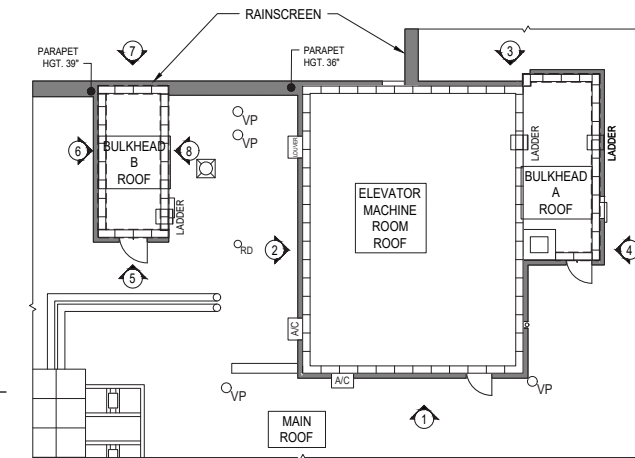

A PARTIAL ROOF PLAN AT BULKHEAD &  
ELEVATOR MACHINE ROOM  
SCALE: 3/32" = 1'-0"

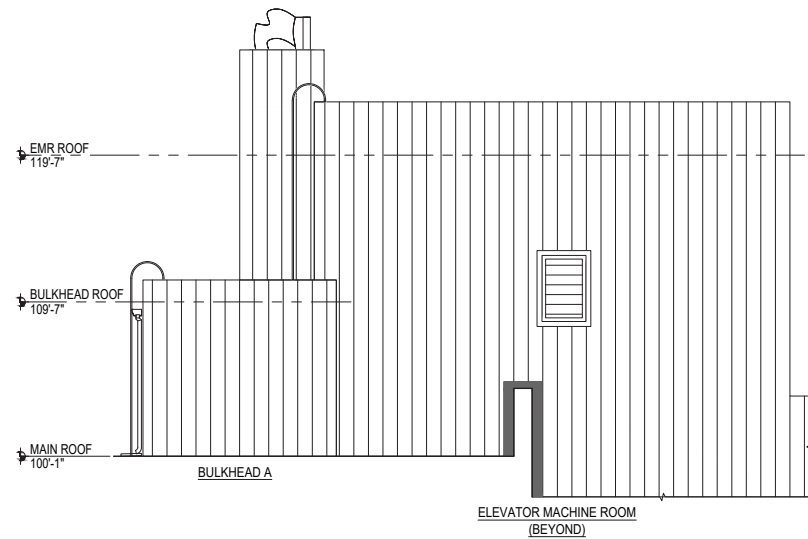

3 EAST ELEVATION  
AT EMR & BULKHEAD A  
SCALE: 3/16" = 1'-0"

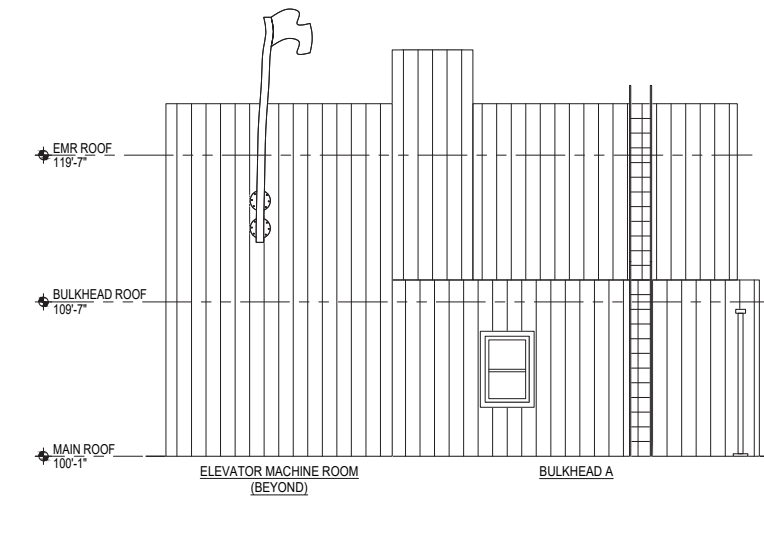

4 SOUTH ELEVATION  
AT EMR & BULKHEAD A  
SCALE: 3/16" = 1'-0"

- Replace roofing membrane
- Install PV panels
- Replace coping stones at bulkheads
- Replace doors and windows
- Install rainscreen
- Replace steel ladders

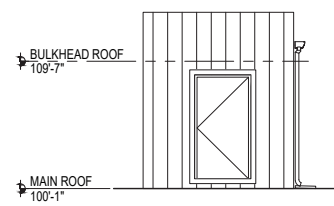

5 WEST ELEVATION  
AT BULKHEAD B  
SCALE: 3/16" = 1'-0"

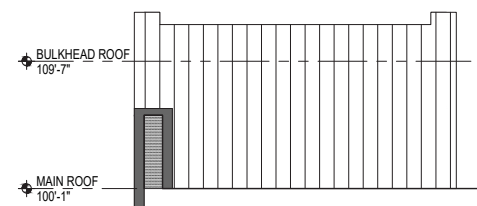

6 NORTH ELEVATION  
AT BULKHEAD B  
SCALE: 3/16" = 1'-0"

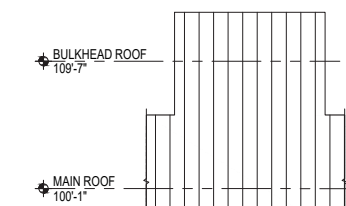

7 EAST ELEVATION  
AT BULKHEAD B  
SCALE: 3/16" = 1'-0"

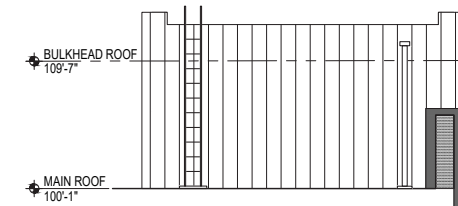

8 SOUTH ELEVATION  
AT BULKHEAD B  
SCALE: 3/16" = 1'-0"



# PROPOSED WALL SECTIONS

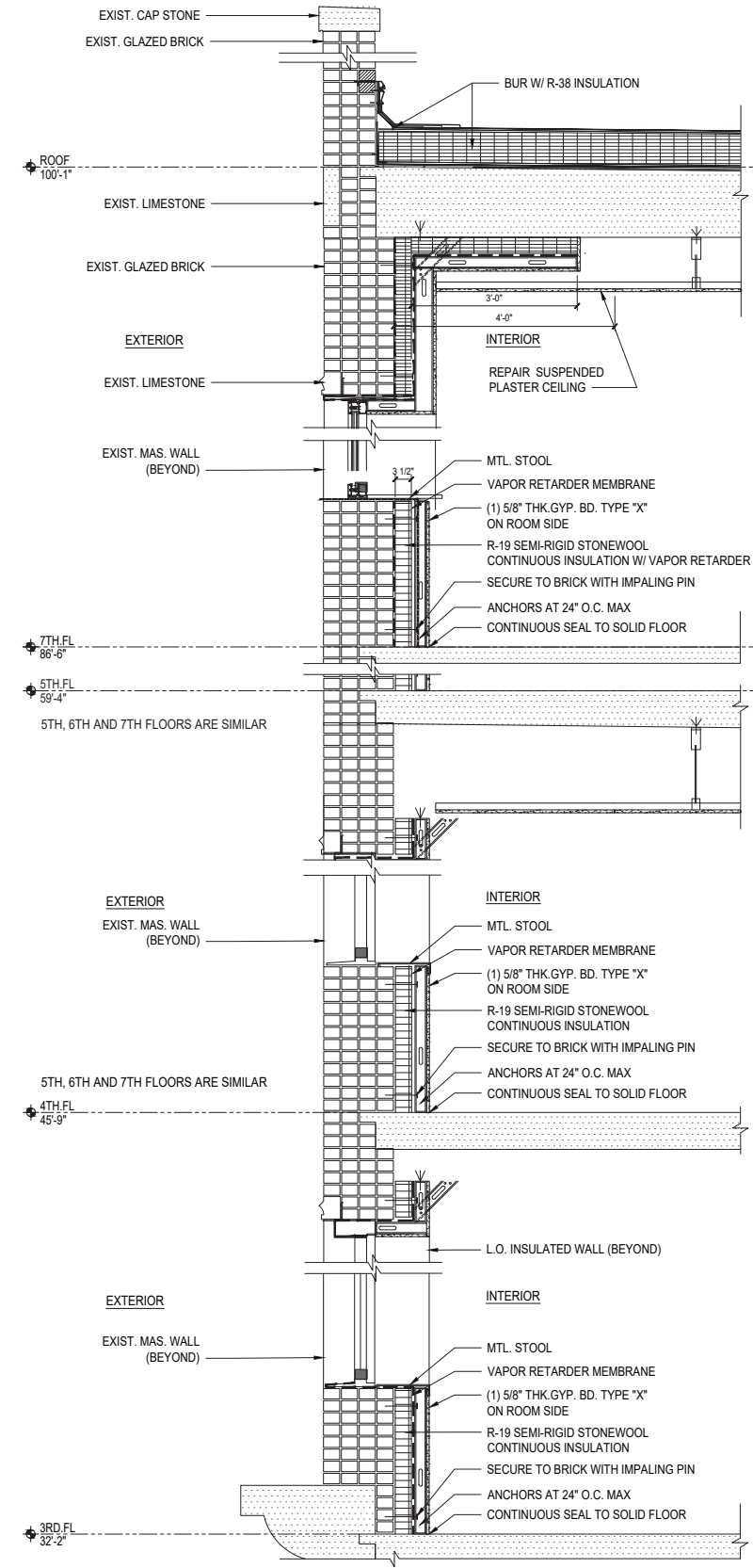
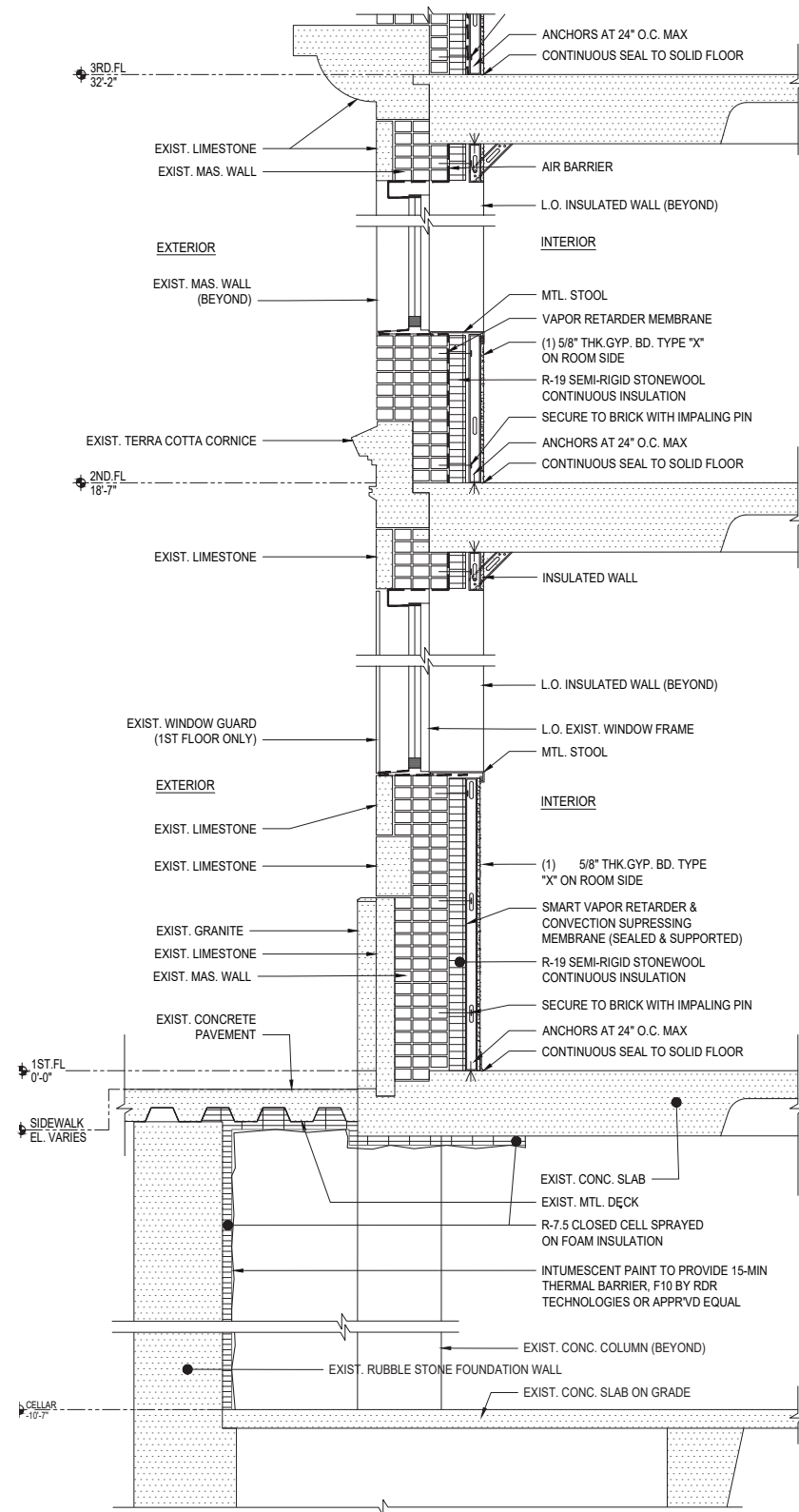

# PROPOSED WALL SECTIONS

